

Instructions for Use Installation and Servicing

To be left with the user

Chatsworth 4 BBU

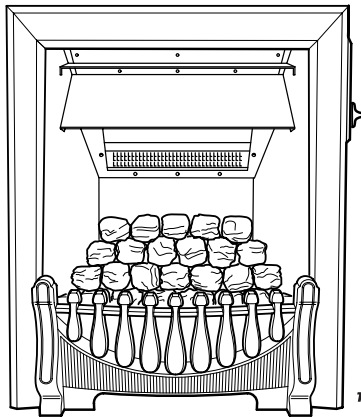

Standard
Frame
illustrated

Brass Standard Frame
Black Wide Frame
Brass/Black Wide Frame
Silver/Black Wide Frame



Dovedale 4 BBU

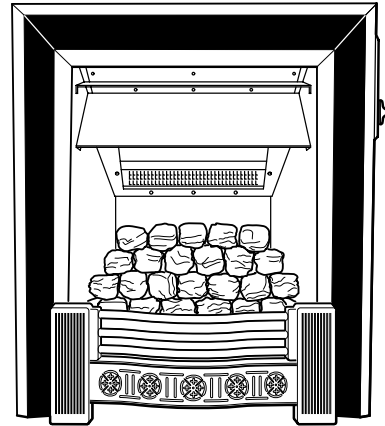

Brass/Black Wide Frame

7625

Used with

**Glow-worm BBU 45/4 and
Glow-worm BBU 54/4**

The instructions consist of three parts, User, Installation and Servicing Instructions, which includes the Guarantee Registration Card. The instructions are an integral part of the appliance and must, to comply with the current issue of the Gas Safety (Installation and Use) Regulations, be handed to the user on completion of the installation.

Guarantee Registration

Thank you for installing a new Glow-worm appliance in your home.

Glow-worm appliances' are manufactured to the very highest standard so we are pleased to offer our customers' a Comprehensive First Year Guarantee.

In the centre pages are to be found your Guarantee Registration Card, which we recommend you complete and return as soon as possible.

If this card is missing you can obtain a copy or record your registration by telephoning the Heatcall Customer Service number 01773 828100.

Our Guarantee gives you peace of mind plus valuable protection against breakdown by covering the cost of:

- All replacement parts**
- All labour charges**
- All call-out charges**

**REGISTER YOUR GLOW-WORM APPLIANCE
FOR 1ST YEAR GUARANTEE PROTECTION**

CALL 0208 247 9857

HEATCALL Customer Services:
Tel: (01773) 828100
One Contact Local Service Fax: (01773) 828070

Hepworth Heating Ltd.,
Nottingham Road, Belper, Derbyshire. DE56 1JT
General/Sales enquiries:
Tel: (01773) 824141 Fax: (01773) 820569

Important Information

Certification

This fire front is certificated for safety and performance. It is, therefore, important that no alteration is made to the fire front, without permission, in writing, from Hepworth Heating Ltd.

Any alteration that is not approved by Hepworth Heating Ltd., could invalidate the certification, the warranty and could infringe the statutory requirements.

CE Mark

The CE mark on this appliance shows compliance with:

1. Directive 90/396/EEC on the approximation of the Laws of the Member States relating to appliances burning gaseous fuels.
2. Directive 73/23/EEC on the harmonization of the Laws of the Member States relating to electrical equipment designed for use within certain voltage limits.
3. Directive 89/336/EEC on the approximation of the Laws of the Member States relating to electromagnetic compatibility.

INFORMATION FOR THE INSTALLER AND SERVICE ENGINEER.

Under Section 6 of the Health and Safety at Work Act 1974, we are required to provide information on substances hazardous to health. The Adhesives and sealants used in this appliance are cured and give no known hazard in this state.

REFRACTORY CERAMIC FIBRE

This product uses fuel effect Pieces containing Refractory Ceramic Fibre (RCF), which are man-made vitreous silicate fibres. Excessive exposure to these materials may cause temporary irritation to eyes, skin and respiratory tract, consequently, it makes sense to take care when handling these articles to ensure that the release of dust is kept to a minimum.

To ensure that the release of fibres from these RCF articles is kept to a minimum, during installation and servicing we recommend that you use a HEPA filtered vacuum to remove any dust and soot accumulated in and around the fire before and after working on the fire. When replacing these articles we recommend that the replaced items are not broken up, but are sealed within heavy duty polythene bags, clearly labelled as RCF waste. This is not classified as "hazardous waste" and may be disposed of at a tipping site licensed for the disposal of industrial waste. Protective clothing is not required when handling these articles, but we recommend you follow the normal hygiene rules of not smoking, eating or drinking in the work area and always wash your hands before eating or drinking.

INSULATION and SEALS

Ceramic fibre and glass fibre used in insulation panels rope and gaskets.

These can cause irritation to skin, eyes and the respiratory tract.

If you have a history of skin complaint you may be susceptible to irritation. High dust levels are usual only if the material is broken.

Normal handling should not cause discomfort, but follow normal good hygiene and wash your hands before eating, drinking or going to the lavatory.

If you do suffer irritation to the eyes or severe irritation to the skin seek medical attention.

Spare Parts

REMEMBER, When replacing a part on this appliance, use only spare parts that you can be assured conform to the safety and performance specification that we require. Do not use reconditioned or copy parts that have not been clearly authorised by Hepworth Heating Ltd.

CONTENTS	DESCRIPTION	SECTION	PAGE No.
INSTRUCTIONS FOR USE	Introduction		3
	Lighting the Boiler and Fire Front		4
	Cleaning		6
INSTALLATION INSTRUCTIONS	General Data	1	8
	Types of Installation and Flue	2	10
	Installation	3	11
	Lighting, Testing and Fitting of Internal Parts	4	12
	Instructions to User	5	16
SERVICING INSTRUCTIONS	Servicing	6	16
	Fault Finding	7	19
	Replacement Parts	8	20
	Spare Parts	9	23

Instructions for Use

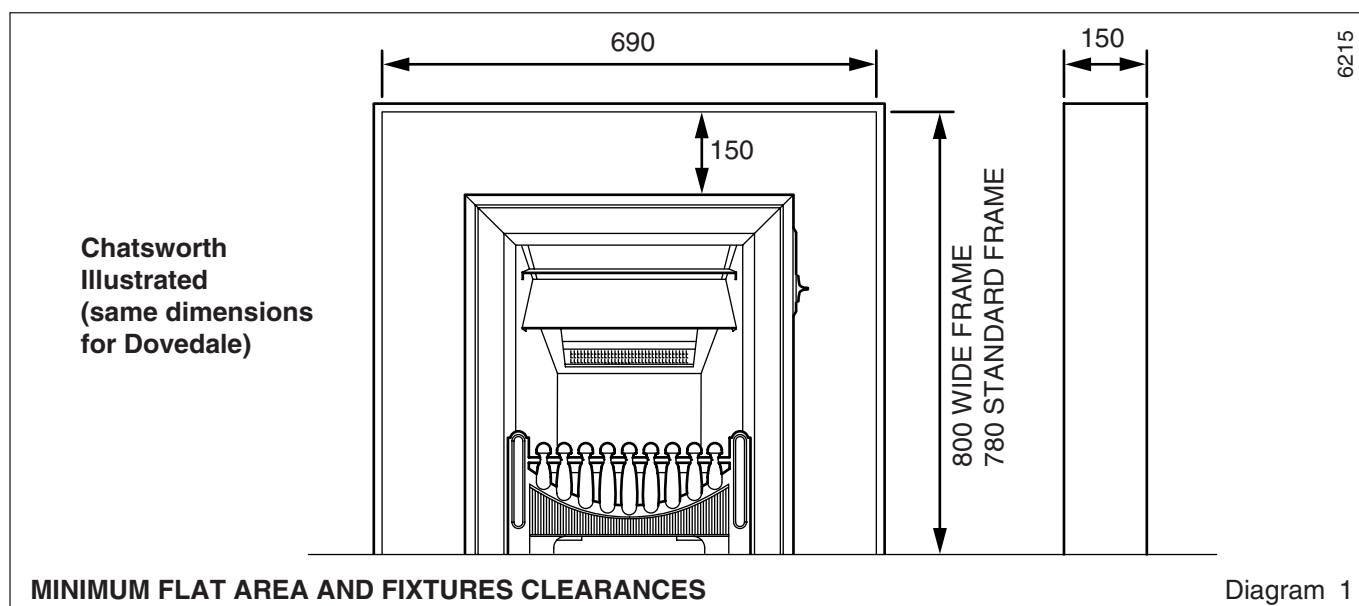

The Gas Safety (Installation and Use) Regulations

In your interests and that of safety it is the Law that ALL gas appliances are installed by a competent person in accordance with the current issue of the above regulations.

Glow-worm Dovedale BBU or Chatsworth BBU with Glow-worm BBU 45/4 or BBU 54/4.

These instructions should be read and carefully followed for the safe and economical use of your combined fire front and central heating boiler.

The fire front can be used only with special Glow-worm 45/4, 54/4 Back Boiler Units.

Chatsworth (black only). The brass coloured badge on the appliance can be replaced with a black badge, which is supplied in fret pack.

The fire front and back boiler must be installed as a complete appliance.

The boiler and fire front can be used either together or independently.

In the event of a power failure the fire front can still be used on its own, see "Lighting the Fire Front".

Important Notice

This appliance is for use only on G20 gas.

A slight smell may occur, for a short time, after initial lighting, this is quite normal and it will quickly disappear.

With a little use the interior of the fire front will discolour and acquire the appearance of a solid fuel fire.

CAUTION: Combustible furniture or materials should not be placed closer than 1metre radius in front of the fire front, refer to diagram 1 for side clearances.

Clothing or other flammable material must not be placed on the fire front castings.

Soft wall coverings, for example, blown vinyl wallpaper, are easily affected by heat, they may, therefore, scorch or become discoloured when close to a heating appliance. Please bear this in mind when having a heating appliance installed and when redecorating

WARNING

The fire front has a naked flame.

A fireguard must be used for the protection of children, the infirm or elderly.

A fireguard should comply with the current issue of BS6539 "Fireguards for use with solid fuel appliances" or the current issue of BS6778 "Fireguards for use with portable, free standing or wall mounted heating appliances".

Do not allow any refuse or rubbish to be burnt on this fire front, or any objects to be placed in the flue exit.

Maintenance/Serviceing

To ensure the continued efficient and safe operation of the appliance it is recommended that it is checked and serviced as necessary at regular intervals. The frequency of servicing will depend upon the particular installation conditions and usage, but in general once a year should be enough.

If this appliance is installed in a rented property there is a duty of care imposed on the owner of the property by the current issue of the Gas Safety (Installation and Use) Regulations, Section 35.

It is the law that this work be carried out by a competent person.

To obtain service, please call your installer or Heatcall (Glow-worm's own service organisation) using the telephone number given on the front page of these instructions.

Regularly make sure that the purpose provided ventilation is free from obstructions.

Please be advised that the 'Benchmark' logbook (supplied with back boiler unit) should be completed by the installation engineer on completion of commissioning and servicing.

All CORGI Registered Installers carry a CORGI ID card, and have a registration number. Both should be recorded in your boiler Logbook. You can check your installer is CORGI registered by calling CORGI direct on :- 01256 372300.

Heat Output - Fire Front

The gas fire front will work for about 4 hours 20 minutes at full on rate on one therm of gas. The price of a therm of gas will vary according to the tariff.

See also "Lighting the Fire Front"

Gas Leak or Fault

If a gas leak or fault exists or is suspected the appliance **MUST** be turned off, including the electrical supply and **MUST NOT BE USED UNTIL THE FAULT HAS BEEN PUT RIGHT.** Advice/help should be obtained from your installation or servicing company or the local gas undertaking.

Instructions for Use

Clearances

A shelf or surround of a maximum depth of 150mm may be fitted, provided that clearances are as diagram 1, however, for every extra 25mm above the fire front the depth of the shelf may be increased by 25mm.

On no account may carpet or other combustible material be laid directly under the fire front.

Frost

If the boiler is to be out of use for any long time during severe weather conditions we recommend that the whole of the system, including the boiler be drained off to avoid the risk of freezing up.

If fitted, switch off the immersion heater in the domestic hot water cylinder.

If you are in doubt your installation or servicing company or the local gas undertaking should be contacted.

Electrical Supply

WARNING. The appliance must be earthed.

Connection of the appliance and any system controls to the mains (230V~50Hz) must be through a 3A fused double pole isolating switch, having a minimum double pole contact separation of 3mm, serving only the boiler and system controls.

The colours of three core flexible cable are, Brown - live, Blue - neutral, Green and yellow - earth.

Safety Device.

This appliance is fitted with a flue blockage safety device which will shut down the appliance in the event of abnormal flue conditions. This device is NOT a substitute for an independently mounted Carbon Monoxide detector.

If the boiler or fire front shut down frequently, for no apparent reason, the first things that must be checked are the chimney and air inlets into the room.

An additional cause of the fire shutting down could be that the filter in the gas tap is blocked.

Any problems found must be put right, by a competent person, before the boiler and fire front are used again.

If the burners go out, wait three minutes before relighting, but check as above.

Lighting the Boiler

The boiler user control is placed behind the ashpit cover.

To remove the ashpit cover unhook from the fret.

Refer to diagram 2 to identify the boiler user control.

See that all other controls are calling for heat.

The clock, room thermostat and programmer, if fitted, will probably be some distance away from the unit.

To see how these items work and need to be set, read the manufacturers instructions supplied with them.

Turn the control thermistor knob "A" fully anti-clockwise so that the pointer is against the "Reset" position on the boiler user control panel, see diagram 2.

Switch on electrical supply to the back boiler.

There will be a purge for approximately 30 seconds.

NOTE: If the electrical supply is switched rapidly off and on without gas present the control will purge for 100 sec. Neither of the indicators will be lit. The appliance will then operate correctly.

The boiler will automatically light.

This is indicated by a green light on the boiler user control panel coming on, see diagram 2.

Note: Should the red light on the boiler user control panel come on, it indicates that the pilot light is not operating correctly, or the flue blockage safety device has been activated.

When the fault has been corrected, turn the control thermistor knob "A" fully anti-clockwise so that the pointer is against the "Reset" position on the boiler user control panel, see diagram 2.

NO ATTEMPT SHOULD BE MADE TO RELIGHT THE BOILER UNTIL ANY FAULT HAS BEEN CORRECTED. EXPERT ADVICE SHOULD BE SOUGHT.

Adjust the control thermistor knob to the required setting between the minimum and maximum position.

Maximum is approximately 82-C.

The temperature of the hot water cylinder should be periodically raised to 60-C.

Check that all external controls are also set to your requirements.

If the burner goes out for no apparent reason it is **IMPORTANT** that the advice given under "Safety Device" is followed.

To turn the boiler off

For short periods, turn the control thermistor knob "A" fully anti-clockwise so that the pointer is against the "Reset" position on

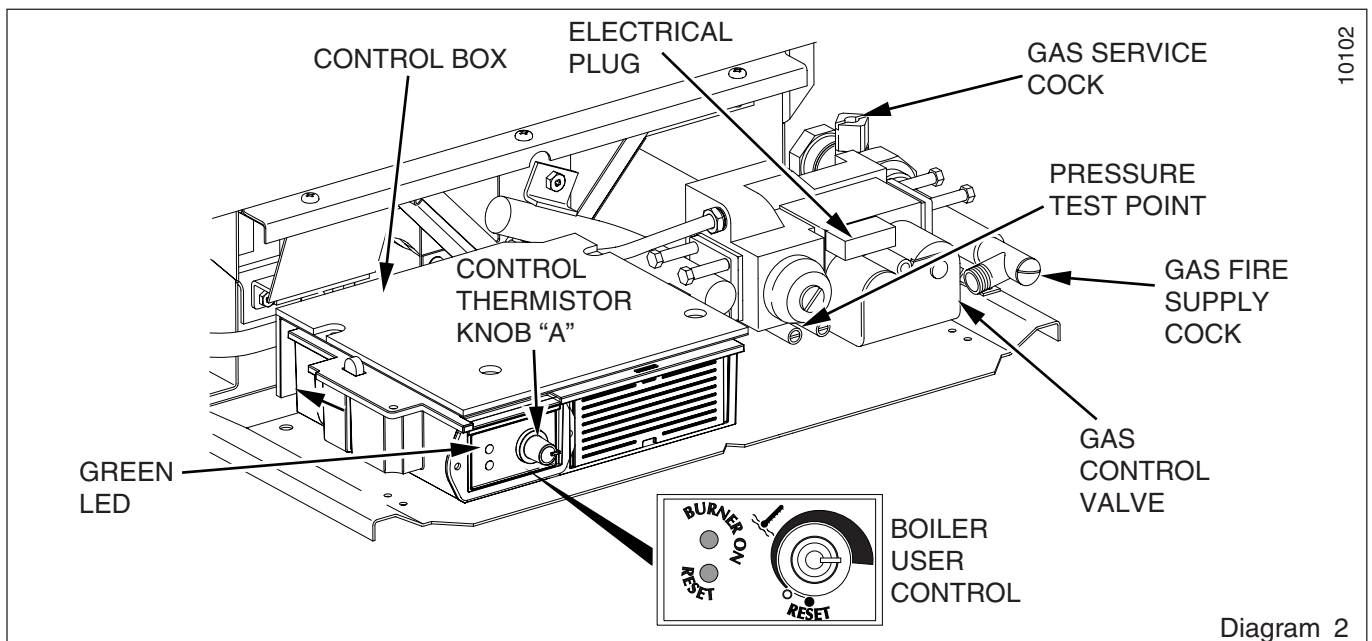

Instructions for Use

the boiler user control panel, see diagram 2.

The pilot will remain alight if there is a call for heat. To relight the main burner turn control thermistor knob "A" clockwise to the desired setting between the minimum and maximum position.

For longer periods, turn control thermistor knob "A" anti-clockwise so that the pointer is against the "Reset" position on the boiler user control panel. Switch off the electrical supply to the appliance.

To relight follow the full lighting instructions given above.

Lighting the Fire Front

Please read the information about the safety device at the beginning of these User Instructions before lighting the fire.

IMPORTANT If the burner does not light (instructions below) within three seconds, return the knob to the OFF position, wait for 10 seconds and repeat the following lighting operation.

1) Slide the control knob down to the "ignition position", against its stop and hold in position, see diagram 2, clicking of the ignition will be heard and the burner will light.

2) Keep the knob in the ignition position for fifteen seconds after the burner has lit. The ignition system will continue to operate, indicated by the clicking at this time.

Note: Before releasing, ensure the control knob is against its stop, to engage the flame supervision device.

3) Move the control knob to the desired position.

Note: Setting 1 is Low, Setting 3 or Coke is High.

To change settings, refer to diagram 3.

Note: Coke setting gives off a high glow, but a low flame effect.

If the burner goes out, wait three minutes before relighting, for any other reason wait for two minutes.

Lighting the Fire with a Match or Spill

As a temporary measure the fire may be lit with a spill or long match as follows:-

WARNING. Take care as the burner has a naked flame.

Hold a lighted spill or long match and put it into the hole as shown in diagram 4. Position the spill so that the flame is over the burner.

Keep the spill in place, slide the control knob down to the "ignition position", against its stop and hold, see diagram 3, the burner will light, remove the spill.

Keep the knob in the ignition position for fifteen seconds after the burner has lit.

Before releasing, ensure the control knob is fully depressed against its stop, to engage the flame supervision device.

Once lit move the control knob to the desired setting.

Note: Setting 1 is Low, Setting 3 or Coke is High.

Note: Coke setting gives off a high glow, but a low flame effect.

If the burner goes out, wait three minutes before relighting, for any other reason wait for two minutes.

This is a temporary measure only. The ignition system should be repaired or the battery be replaced as soon as possible.

Soot Accumulation

Note: A small amount of soot accumulating is quite natural and will give the fire a more realistic effect.

If desired, these minor soot deposits can be burned off by running at the coke setting for approx. one hour.

Lighting the Boiler

The boiler controls are placed behind the ashpit cover.

To remove the ashpit cover unhook from the fret.

Refer to diagram 2 to identify the boiler controls.

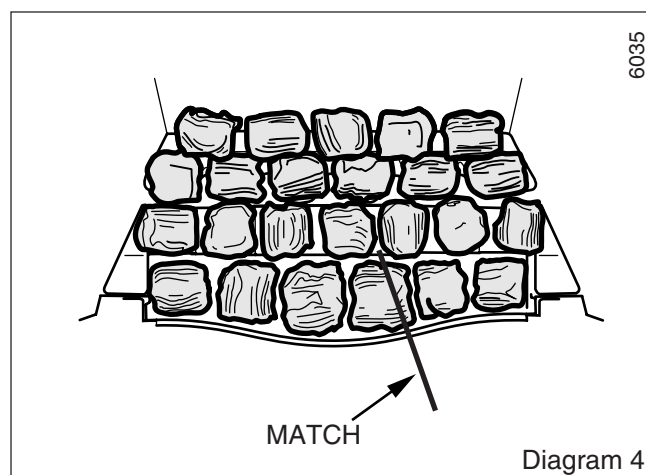
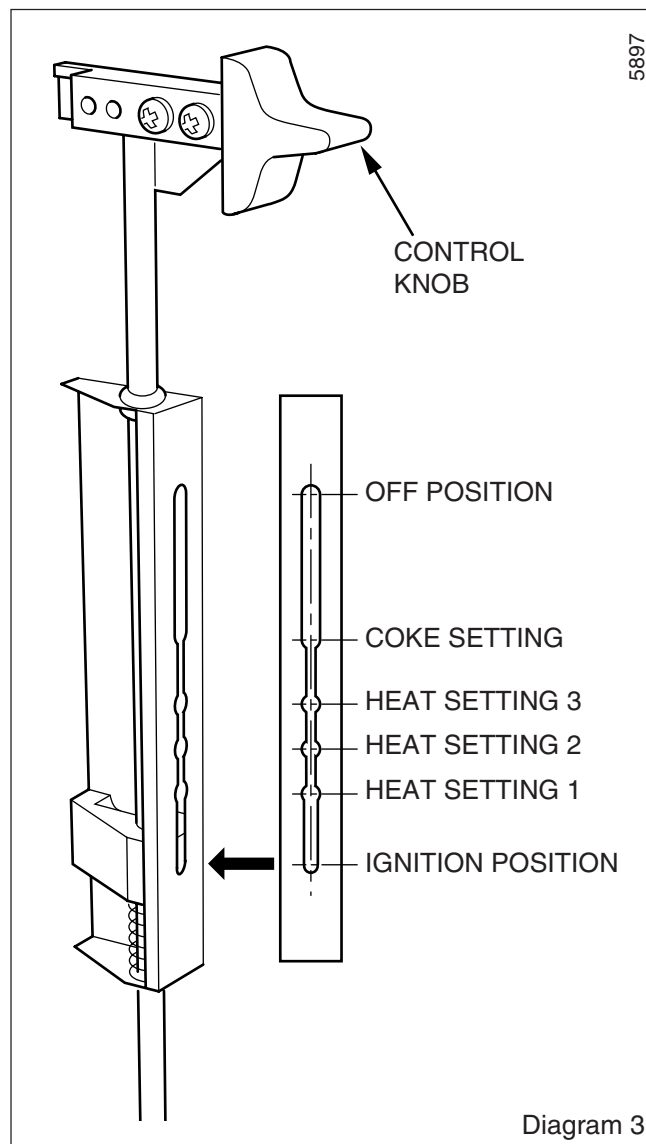

Instructions for Use

Cleaning your Fire

WARNING. This fire contains metal parts (components) and care should be taken when handling and cleaning, with particular regard to edges.

Any cleaning must only be done when the fire is cold.

If large pieces of debris are found the chimney should be inspected and the fire serviced before further use.

Under normal conditions dusting the surrounds of the fire should be enough. An occasional wipe over with a damp cloth will help to remove any marks.

Do not use an abrasive cleaning powder or liquid.

To Clean the Fuel and Fuel Supports - this can be done by the User

Should any soot accumulation become excessive, the fuel effect pieces should be removed from the fire for cleaning. Cleaning should be carried out in a well ventilated area or in the open air, by gently brushing with the pieces held away from your face so that you avoid inhaling the dust. We do not recommend the use of a normal domestic vacuum cleaner, which may blow dust back into the air.

Remove the fret and ash pit cover, see diagram 5.

Take care not to damage the frame.

Following steps 1 to 8 in reverse order, remove the fuel effect pieces and fuel effect supports, see diagram 6.

Be careful as with use they become fragile.

Clean the fuel effect pieces and fuel effect supports with a soft brush, as above.

With the fuel effect pieces and fuel effect supports removed, the base of the appliance **may** be cleaned with a vacuum cleaner.

Note: After cleaning, always adhere strictly to the instructions when reassembling the fuel effect supports and fuel effect pieces.

Use only the fuel effect approved for this fire.

Do not use more fuel effect pieces than specified.

Fuelbed Fitting

CAUTION. If the fuel effect supports and fuel effect pieces are damaged, do not light the fire or further test until replacement parts are fitted.

USE ONLY THE FUEL EFFECT APPROVED FOR THIS FIRE.

DO NOT USE MORE FUEL EFFECT PIECES THAN SPECIFIED.

DO NOT CHANGE THE LAYOUT OF THE FUEL EFFECT PIECES.

The importance of positioning the fuel effect pieces correctly cannot be overemphasised if sooting is to be avoided. The flame effect may also be impaired and the life of the fuel effect pieces reduced if assembly directions are not followed.

Before positioning the fuel effect pieces, study carefully the illustrations showing the layout procedure of the pieces, see diagram 6.

Follow the steps which are shown numerically in the fuelbed fitting sequence starting at Step 1, making sure that each stage is completed before carrying on to the next and that all written instructions are adhered to, see diagram 6.

STEP 1. When fitting the front support make sure the feet are located at the back of the retaining lip and the support fits between the brackets.

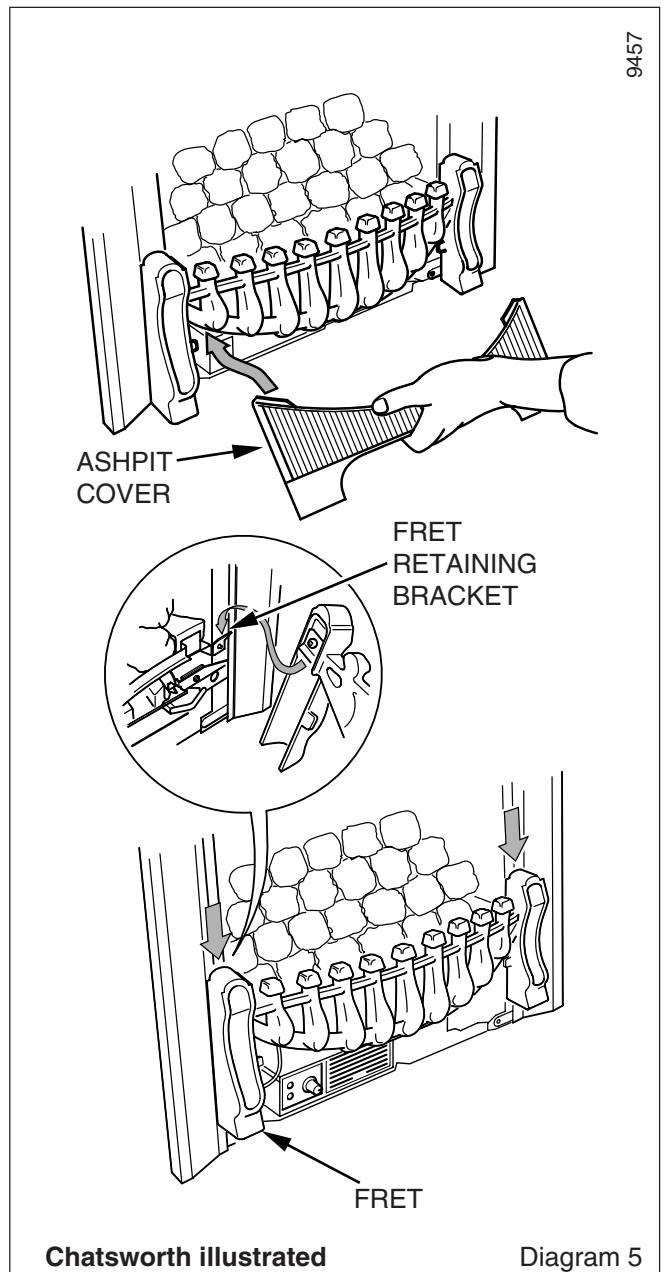

STEP 2. Fit the side supports tightly into the front corners touching the side and front of the appliance.

STEP 3. Fit the rear support, making sure it sits on the bottom of the brackets, by pushing it down firmly.

STEP 4. Fit the middle support over the burner making sure it sits behind the brackets on the burner. Keep the support clear of the cross lighting ports.

STEP 5. Place the two large fuel effect pieces with the flat bases and round indents down. Leave gaps around the pieces.

NOTE: The remaining fuel effect pieces can be turned as requires to maintain a constant gap around each fuel effect piece.

STEP 5 CONTINUED. Place four small fuel effect pieces starting from the outside, leaving gaps around the pieces. The left hand outside piece must touch the side of the fire. The right hand outside piece must touch the left hand side of the burner support bracket.

STEP 6. Place seven small fuel effect pieces on the middle support starting from the outside, leaving gaps around the pieces. The two outside pieces touch the sides of the fire.

Instructions for Use

5982

STEP 1 - Front support

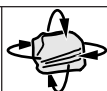
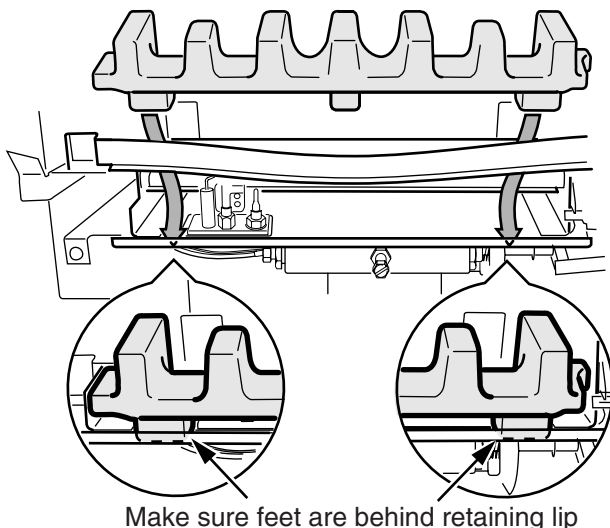

NOTE : The fuel effect pieces can be rotated to achieve a random effect.

STEP 5 - 2 Large & 4 small fuel effect pieces

IMPORTANT Leave 3mm gap between all fuel effect pieces and middle support

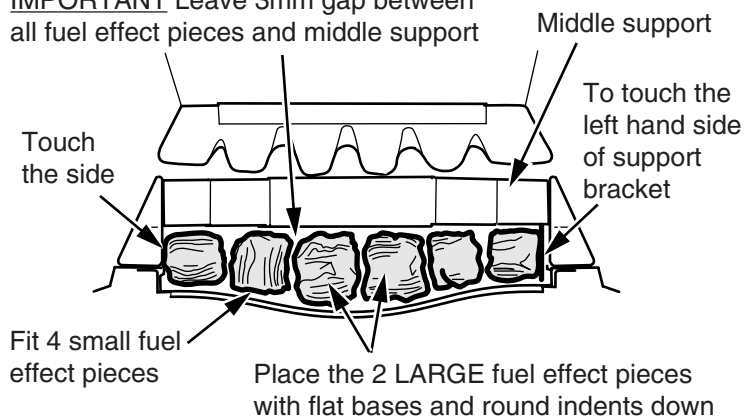

STEP 2 - Side supports

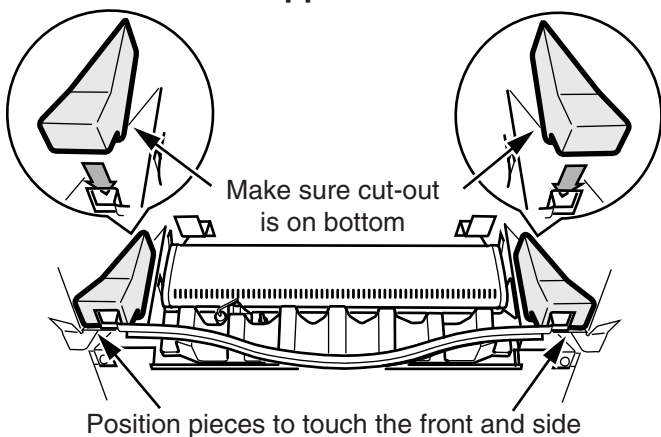

STEP 6 - 7 Small fuel effect pieces

Sit 7 fuel effect pieces on the middle support

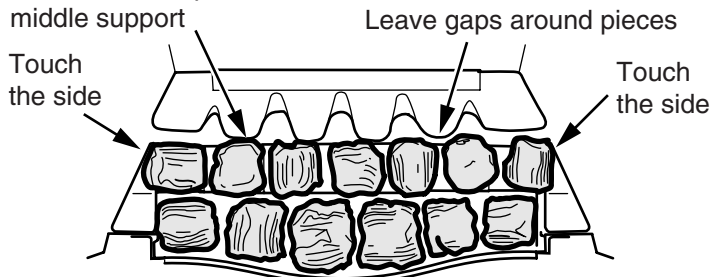

IMPORTANT This row of fuel effect pieces must not overlap the front row of fuel effect pieces. Position as shown on the front edge of the middle support

STEP 3 - Rear support

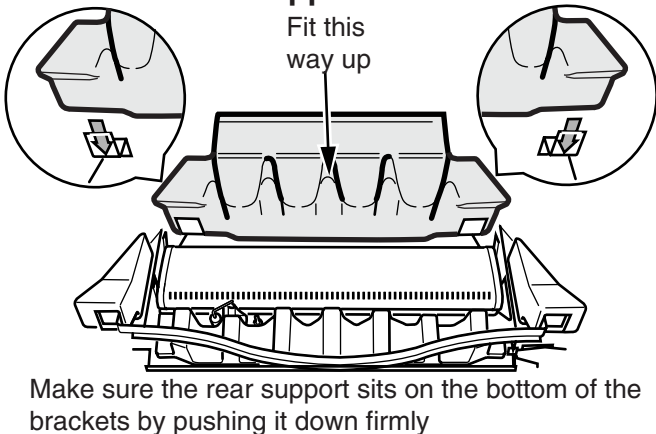

STEP 7 - 6 Small fuel effect pieces

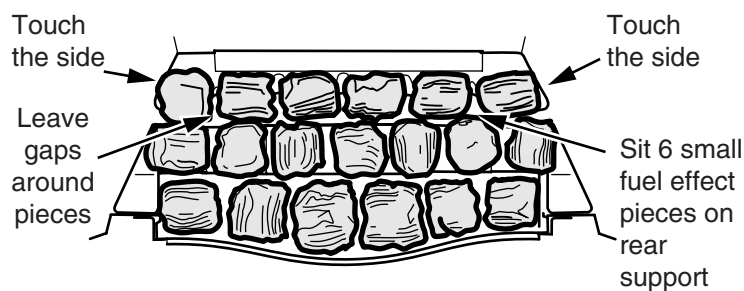

IMPORTANT This row of fuel effect pieces must not overlap the middle row of fuel effect pieces.

STEP 4 - Middle support

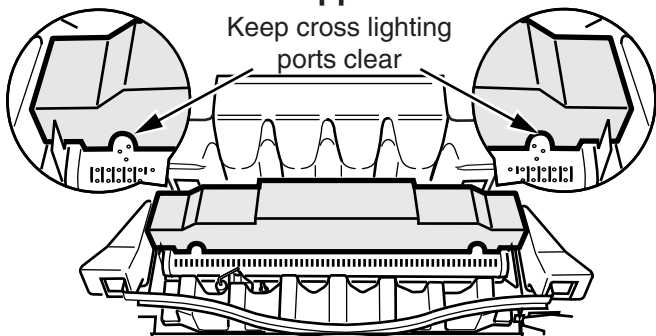

STEP 8 - 5 Small fuel effect pieces

Fit 5 fuel effect pieces they must touch rear of fire

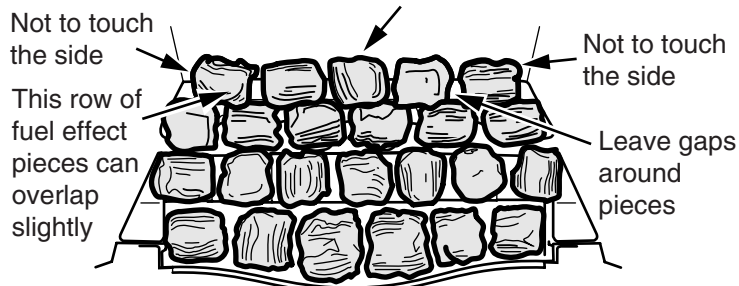

Diagram 6

Instructions for Use

STEP 7. Place six small fuel effect pieces on the six flat areas of the rear support starting from the outside, leaving gaps around the pieces. The two outside pieces touch the sides of the fire.

STEP 8. Place five small fuel effect pieces on the top of the rear support starting from the outside overlapping slightly the previously fitted pieces and touching the rear of the fire. Leave gaps around the front and side of the pieces. The two outside pieces do not touch the sides of the fire.

When you have fitted all the small pieces you may have to adjust some slightly to maintain constant gaps.

To Replace the Battery - this can be done by the user

The battery, supplied, should, under normal usage last for about 18 months.

The replacement is 9V and we recommend that it be of the alkaline type which can be bought locally.

Remove the fret and ash pit cover, see diagram 5.

Replace the battery as shown in diagram 7.

Replacement Parts

If replacement parts are required apply to your local supplier.

Remove the ashpit cover, see diagram 5.

Quote the name of the appliance indicated on the rear of the ashpit cover.

Quote the serial number of the fire front found on the label attached to the chassis to the left of the electrical control box, see diagram 7.

Quote the back boiler units name and serial number on the data label which can be found on the base of the boiler, see diagram 7.

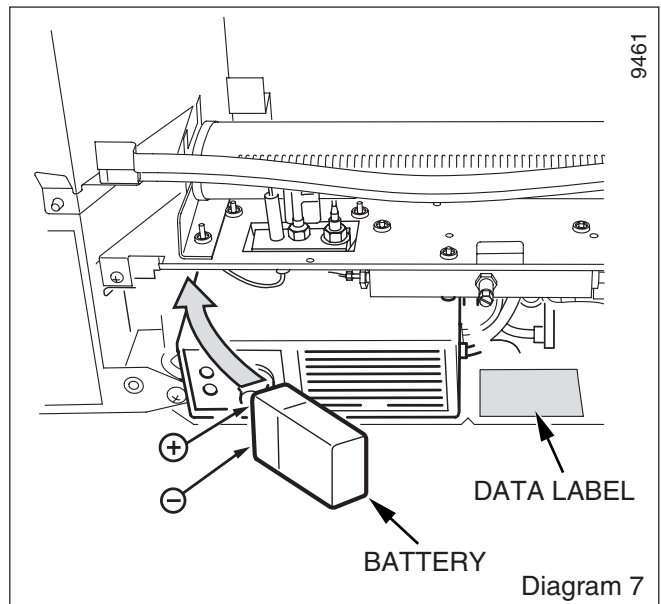

1 General

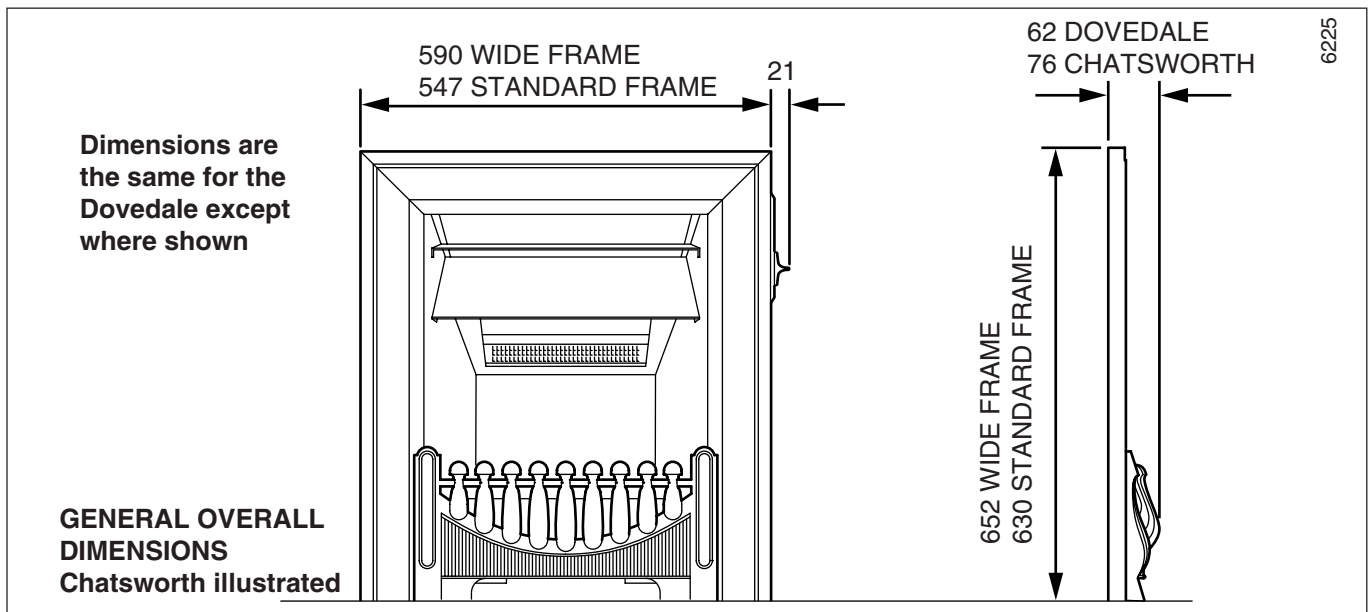

References in these instructions to British Standards and Statutory Regulations and Requirements apply only to the United Kingdom.

For Ireland the rules in force must be used.

1 General Notes and Information

There is one cardboard carton, which contains all the parts necessary for the fitting of the fire front, see diagram 1.4.

Wherever possible, all materials, appliances and components to be used should comply with the requirements of applicable British Standards.

Where no British Standard exists, materials and equipment should be fit for their purpose and of suitable quality and workmanship.

1.1 Important Notice

This fire front is for use only on G20 gas.

The back boiler is supplied pre-set to a maximum heat output setting, for the 45/4 BBU: 11.72 kW (40000 Btu/h), for the 54/4 BBU: 14.21 kW (48500 Btu/h).

These values are permitted and must not be increased when using the boiler in combination with a Chatsworth 4 or a Dovedale 4 firefront.

1 General

A new data label, supplied with fire front loose items pack, must be stuck over the top of the BBU data label, see diagram 1.1. Care must be taken when oversticking the label on top of the original as not to obscure the boiler serial number.

The fire front is fitted with a flue blockage safety device which will shut it down if there is a lack of oxygen. The principle by which this operates is that when there is a depletion of oxygen resulting from a build up of combustion products. The flame on the pilot light will become unstable and lift up off the thermocouple. This will deactivate the mag unit in the gas control valve, cutting off the gas supply.

If the fire shuts down frequently for no apparent reason the first things to check are the chimney and air inlets into the room. Any problems found must be put right, by a competent person, and a full operational test carried out before the fire is used again.

IN ALL cases the room must be ventilated before attempting to relight the fire.

The flue blockage safety device incorporates the electrode, thermocouple and pilot assemblies.

The flue blockage safety device MUST NOT be adjusted or disconnected. It must be serviced strictly in accordance with the instructions in this book. Any unauthorised interference could result in the device failing to operate, creating a potentially dangerous situation. If replacing, use only the correct and approved parts.

Sealed components must not be interfered with.

Servicing instructions and identification of parts is given in Sections 6, 7, 8 and 9.

It is essential that only genuine Glow-worm parts are used.

All WARNINGS and cautions in these instructions must be observed.

Sheet Metal Parts

WARNING. When fitting or servicing this fire front, care should be taken when handling sheet metal parts, to avoid any possibility of personal injury.

1.2 Statutory Requirements

The fitting of this fire front must be done by a competent person, in accordance with the current issue and relevant requirements of:-

Manufacturer's instructions, supplied.

The Gas Safety (Installation and Use) Regulations, The Building Regulations, The Building Standards (Scotland) Regulations, (applicable in Scotland), The Health and Safety at Work Act, The Control of Substances Hazardous to Health, The Electricity at Work Regulations and any applicable local regulations.

Detailed recommendations are contained in the current issue of the following British Standards and Codes of Practice:-

BS1251, BS5440 Part 1 and 2, BS5871, BS6891.

Manufacturer's instructions must not be taken as overriding statutory requirements.

1.3 Certification

This fire front is certificated for performance and safety. It is, therefore, important that no alteration is made to the fire front without permission, in writing, from Hepworth Heating Ltd.

Any alteration that is not approved by Hepworth Heating Ltd., could invalidate the certification, the warranty and could also infringe the statutory requirements.

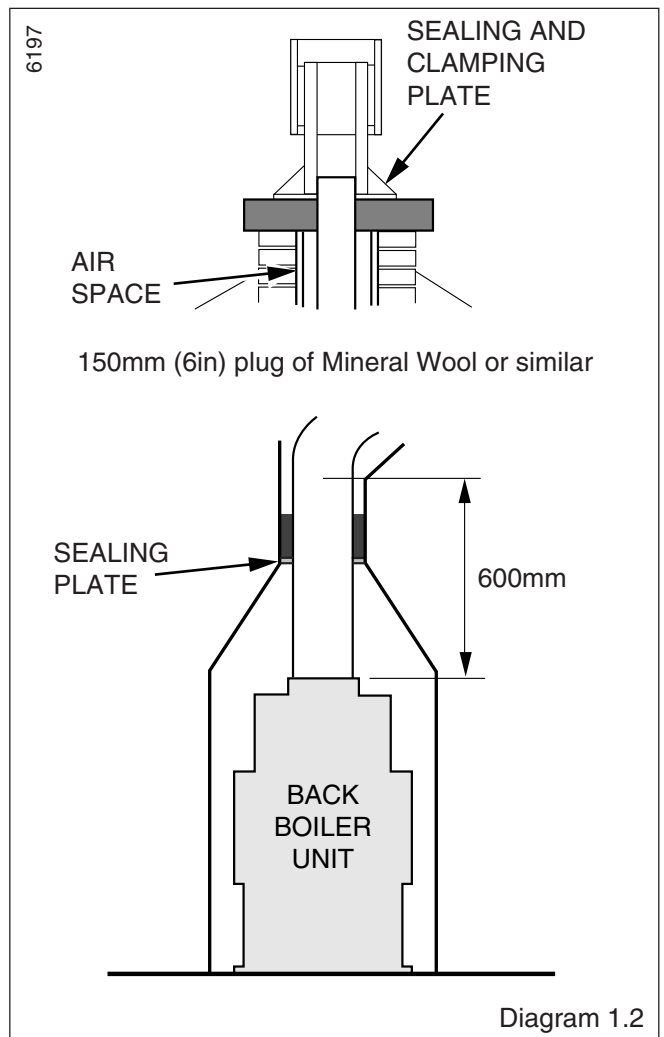
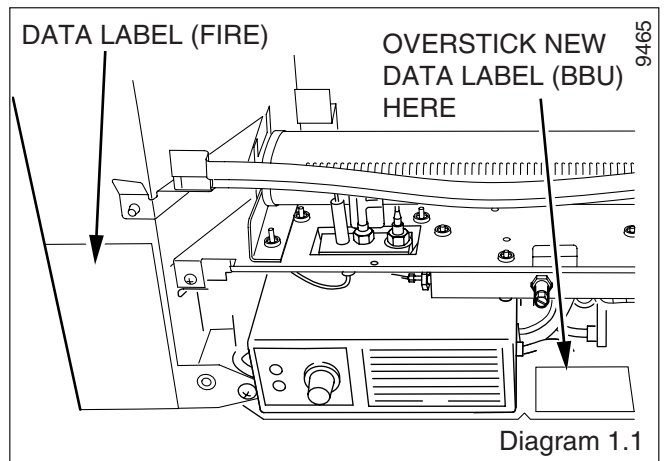

1.4 Data

Injector	Part No. 205739
Pressure setting	Hot 17.6mbar (7.1 in wg)
Heat input nominal	6.74kw (23000 Btu/h)
Total appliance	
Unpacked weight	(Approx. 20kg)
Data label is positioned,	see diagram 1.1.

1.5 Fire Location

This fire front can only be fitted to Glow-worm 45/4 and 54/4 back boiler units which itself has been installed in accordance

1 General

with the Glow-worm Installation and Servicing Instructions for the back boiler.

Before fitting the fire front it is important to make sure that the annular space between the back boiler flue liner and the chimney is sealed at the base and top of the chimney, as shown in diagram 1.2.

The combustion chamber flue spigot assembly projects into the back boiler unit draught diverter assembly.

The gas supply is taken from the fire front gas service cock, located in front of the back boiler unit.

The back boiler must be correctly positioned in the builder's opening as the fire front is located by connection to it.

1.6 Clearances

Restrictions must not be placed around the assembled fire, see diagram 1.3.

A shelf or surround of a maximum depth of 150mm may be fitted, provided clearances are as shown in diagram 1.3. However, for every 25mm extra above the fire the depth of the shelf may be increased by 25mm.

Combustible furniture or materials must not be placed closer than 1metre in front of the fire.

1.7 Unpacking

There is one carton containing all parts necessary for fitting of the fire including draught diverter and blanking plate.

Note: The contents will include either the Chatsworth or Dovedale fret and ashpit cover.

Check contents of loose items pack against packed list.

Reminder: Overstick new data label over BBU data label, see diagram 1.1.

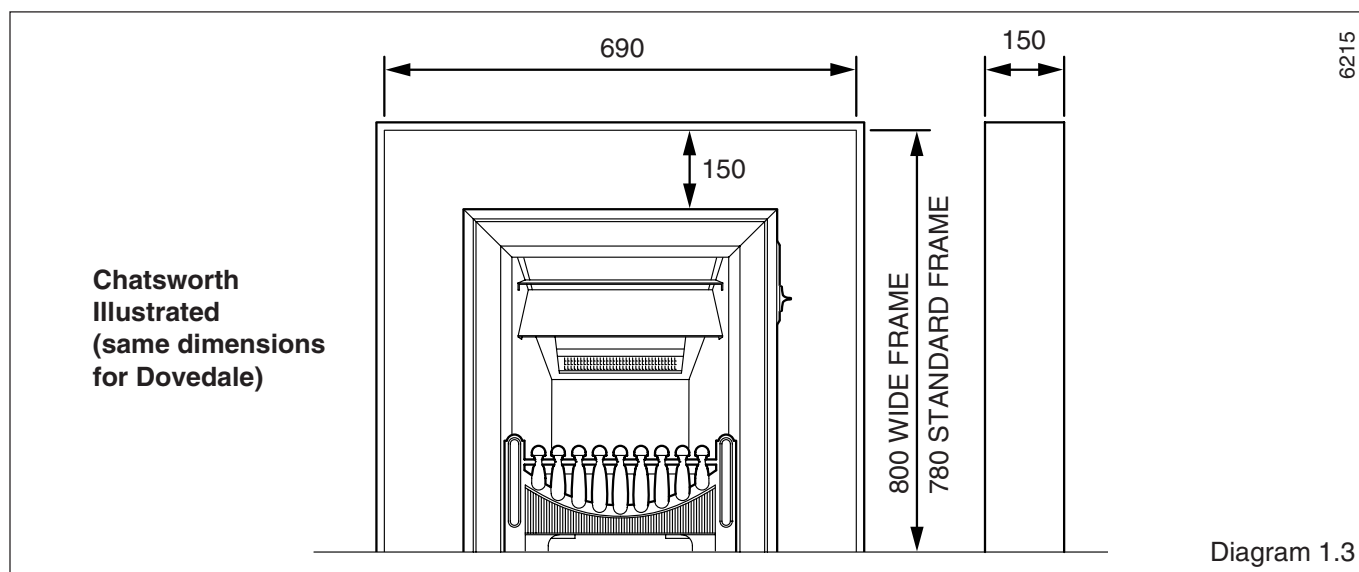

2 Types of Installation and Flue

2.1 Hearth

In ALL cases a fireproof hearth to the minimum dimensions as shown in diagram 2.1, must be fitted.

2.2 With Surround

The surround must have a minimum clear flat area as shown in diagram 1.3. Any projection on the surround must be outside this area.

Any combustible material, for example, blown vinyl wall covering, on the fire front fixing face area must be removed to a height of 625mm and 268.5mm each side of the centre line. These dimensions will allow the standard frame, if fitted, to overlap the remaining wall covering by 5mm.

This area, to the depth removed should then be rendered with a sand/cement mixture.

2.3 Without Surround

The fire front fixing wall face must be flat over an area as shown in diagram 1.3. This also shows the minimum clearances for shelves or projections on the fire front fixing wall face.

The information regarding the fire front opening must be followed together with the last three paragraphs of 2.2. "With Surround".

2.4 Flue and Ventilation

Slide the draught diverter, supplied with the fire, into the draught diverter body on the BBU and secure with two 5mm dog point screws, see diagram 3.2.

The draught diverter assembly accepts the combustion flue assembly.

Note: Provision must have been made during installation of the back boiler for the total ventilation requirement of the combined appliance. See the relevant Section in the Back Boiler Installation and Servicing instructions.

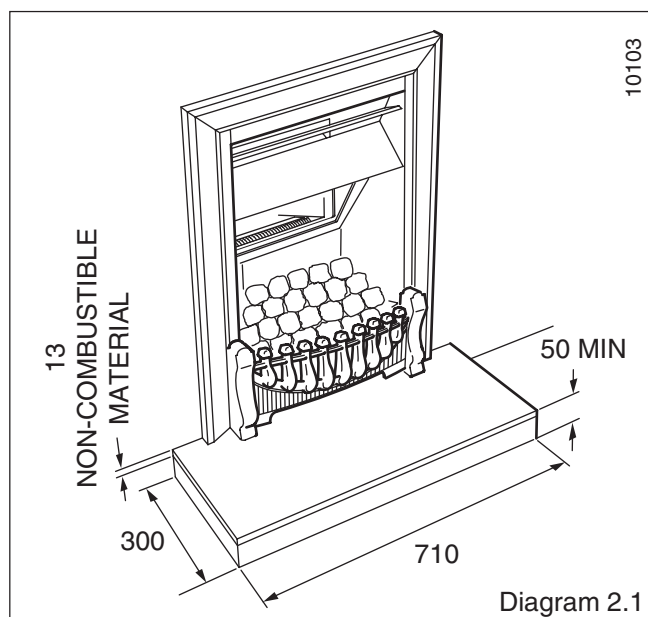

3 Installation

3.1 Positioning the Fire Front

Note: Before fitting, make sure the wall surface to which the fire front is to be fitted is vertical and flat. Any unevenness may cause the whole assembly to become twisted or distorted when fixing.

IMPORTANT. Ensure that the blanking plate, supplied with this fire front, is fitted to the rear of the combustion chamber of the back boiler unit before installing the fire front. Refer to the installation and servicing instructions supplied with the back boiler unit for fitting.

Fit the fire front flue seal supplied in the fittings pack around the outside of the flue spigot, see diagram 3.1.

Fit the fire front wall seal, in three sections, supplied in the fittings pack, first removing the backing strip, see diagram 3.1.

Place the fire front into the fire opening and make sure the flue spigot fits into the draught diverter. Secure the fire front to the back boiler assembly with two wing nuts plus plain washers and the two securing screws provided, see diagram 3.2.

Fire Front Removal

This will be necessary when servicing the back boiler unit.

Disconnect the union nut at the gas fire supply cock, see diagram 3.3.

Remove the two securing screws, slacken the two wing nuts, remove the fire front, see diagram 3.2.

IMPORTANT NOTE: Replace the fire front flue seal if necessary. Ensure the fire front flue seal is fitted before re-fitting the fire front.

3.2 Gas Connection

Connect the gas supply tube, as diagram 3.3 tighten the nut at the gas fire supply cock.

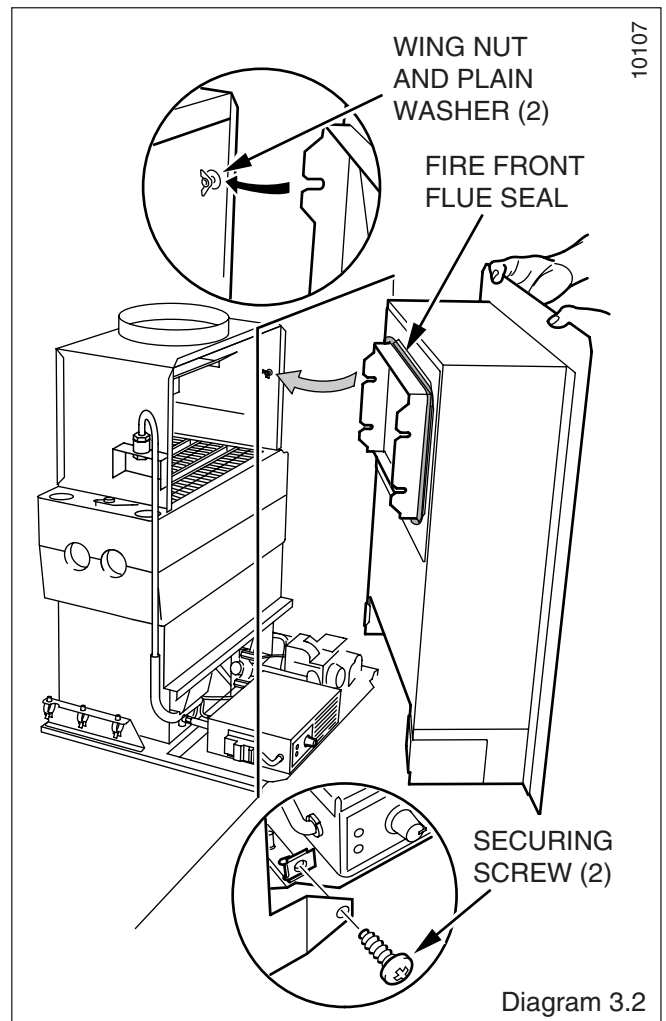

Diagram 3.2

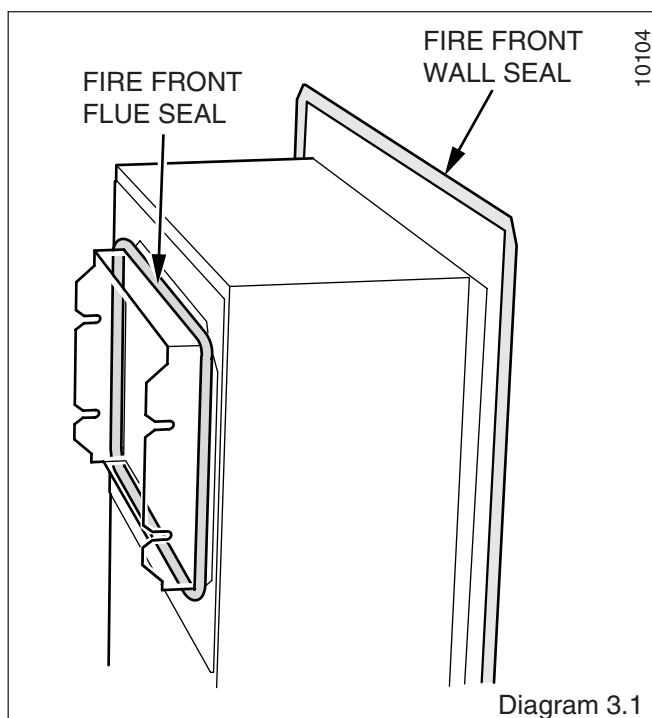

Diagram 3.1

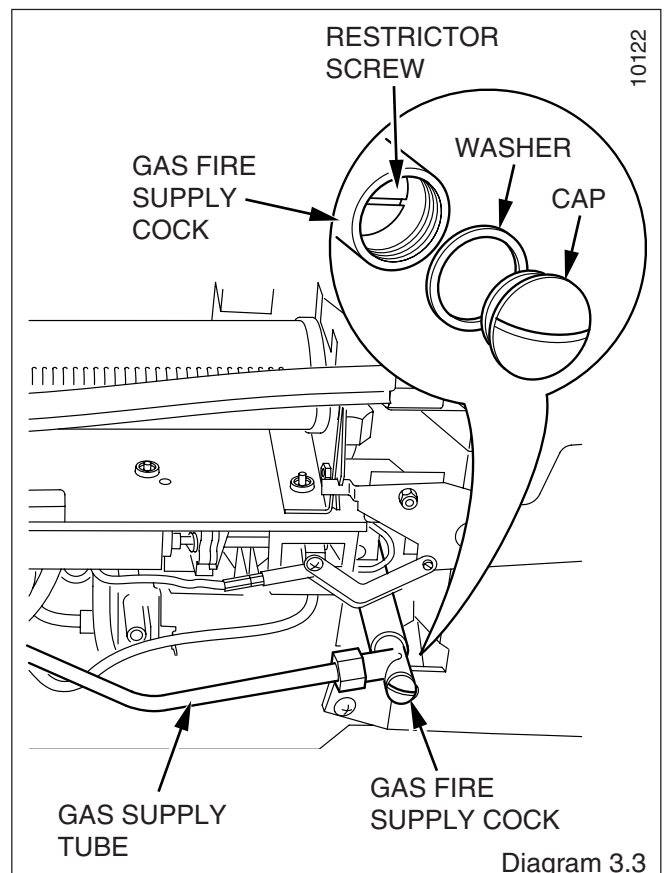

Diagram 3.3

4 Lighting, Testing and Fitting of Internal Parts

Please ensure the "Benchmark" logbook (supplied with back boiler unit) is completed and left with the user.

4.1 Lighting and Testing

The fire is fitted with a safety device.

The information in Section 1 must be observed.

Fit knob to slider control, see diagram 4.1.

The slider control will move up and down, as it does the locator selects positions from off to ignition, see diagram 4.2.

It may be necessary to lubricate the slider plunger with a suitable grease, i.e. Rocol tap grease, Spec. M23600, if the slider is stiff.

Make sure that the gas control assembly is in the OFF position, that is, the slider control is at the top, see diagram 4.2.

Fit the battery, see diagram 4.3.

Remove the pressure test nipple screw and fit a suitable pressure gauge, see diagram 4.4.

Turn the gas supply on at the gas fire supply cock by removing cap and turning restrictor screw anti-clockwise, see diagram 3.3.

To check for gas soundness, apply leak detection fluid to all joints.

WARNING. Take care when doing the following check, as the burner has a naked flame.

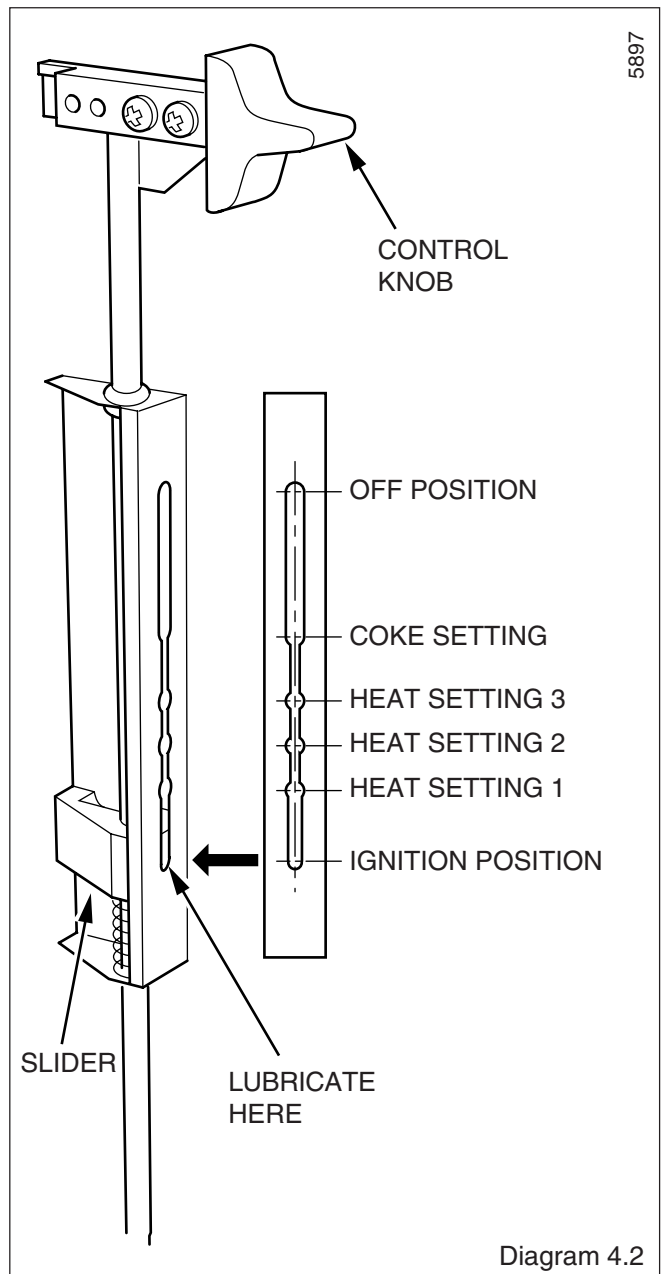
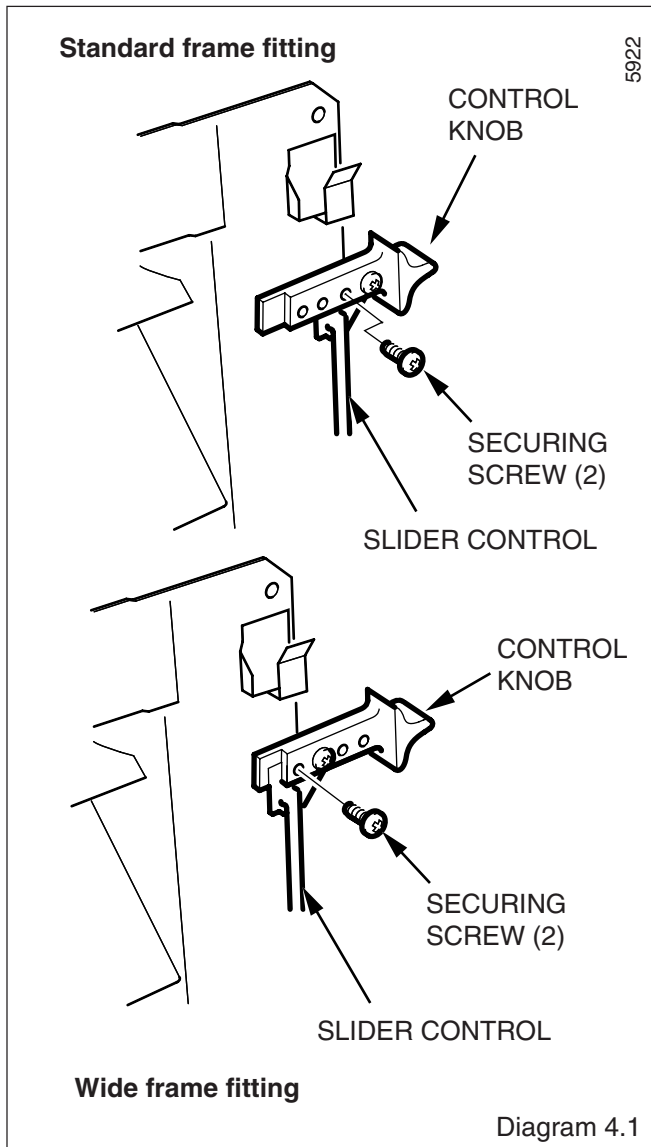

4 Lighting, Testing and Fitting of Internal Parts

Slide the control knob all the way down to the ignition position, against its stop, and hold, see diagram 4.2, clicking of the ignition will be heard and the burner will light.

IMPORTANT If the burner does not light (instructions below) within three seconds, return the knob to the OFF position, wait for 10 seconds and repeat the following lighting operation.

1) Slide the control knob down to the "ignition position", against its stop and hold in position, see diagram 2, clicking of the ignition will be heard and the burner will light.

2) Keep the knob in the ignition position for fifteen seconds after the burner has lit. The ignition system will continue to operate, indicated by the clicking at this time.

Note: Before releasing, ensure the control knob is against its stop, to engage the flame supervision device.

Air may be present in the supply to the fire so that the initial lighting operation may need to be repeated.

With the burner lit, check all joints for gas soundness, at all control positions, in accordance with the current issue of BS6891.

Check that the gas pressure is as stated in the Data Section or on the Data Label.

If there is any doubt about the gas rate, check at the meter, having first turned off all other gas appliances and pilot lights.

The gas rate for this fire at heat setting 3 is 22.68ft/h (0.8m/h).

Check all heat settings, 1, 2, 3 and coke.

To turn the fire off, return the slider control to the top.

Remove the pressure gauge, refit the screw and make sure that a gas tight seal is made.

Chatsworth only - fit the control shield, see diagram 4.5.

4.2 Fire Frame

Remove the frame from the packaging.

Fit as shown in diagram 4.6

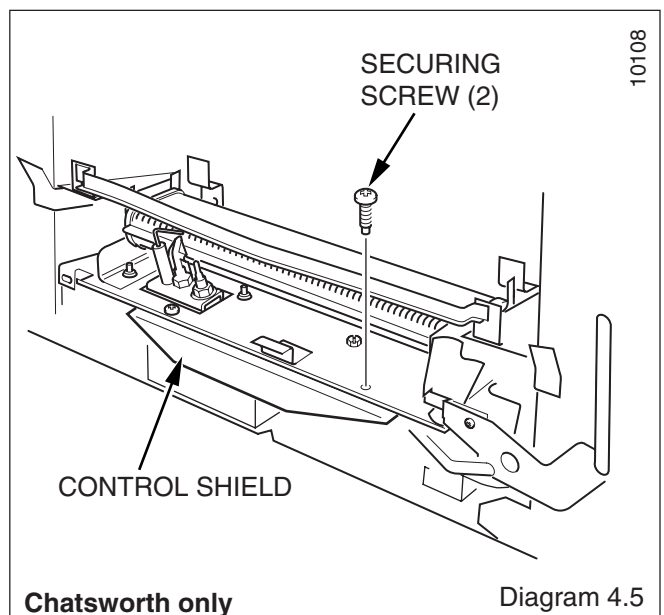
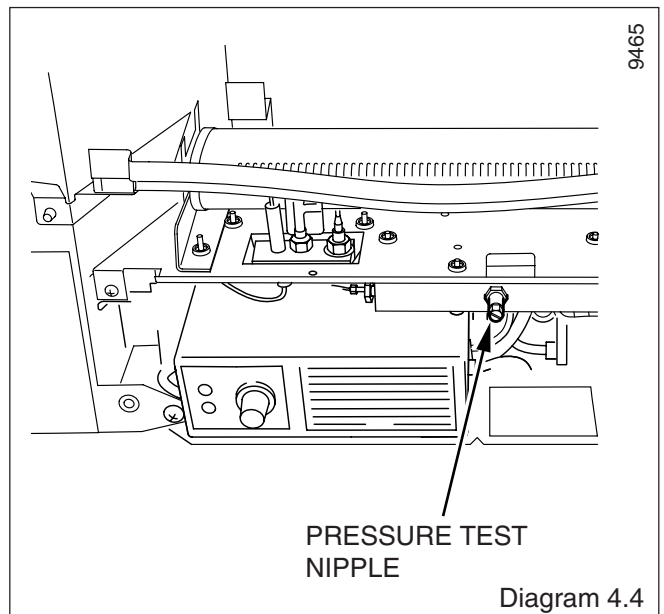
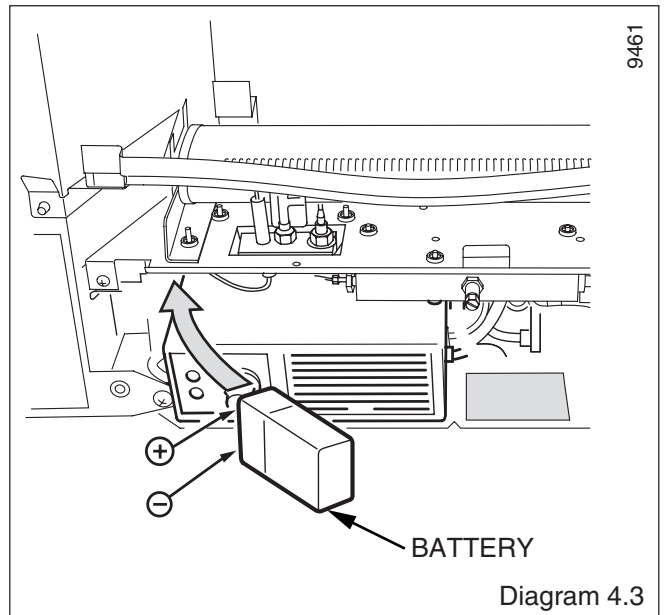

4 Lighting, Testing and Fitting of Internal Parts

4.3 Fuelbed, Fret and Ashpit Fitting

For fuelbed fitting, see Instructions for Use

CAUTION. If the fuel effect supports and fuel effect pieces are damaged, do not light the fire or further test until replacement parts are fitted.

Fit the fret and ashpit cover as shown in diagram 4.7.

Take care not to damage the frame.

Chatsworth (black only). The brass coloured badge on the appliance can be replaced with a black badge, which is supplied in fret pack.

4.4 Heat Settings

Refer to diagram 4.2.

In the unlikely event of the burner going out whilst the fire is on, return the slider to OFF. Wait three minutes before relighting.

If relighting for any other reason wait two minutes before doing so.

4.5 Testing for Clearance of Products

The fire must be fitted with all its parts.

- (a) **WARNING.** The fire front burner has an open flame.
- (b) **WARNING.** Take care. The appliance will get hot during testing.
- (c) For the test you will need a smoke match and an extension.
- (d) **IN ALL CASES,** if spillage continues after the specified test periods steps must be taken to rectify the fault(s).

Possible causes include, flue obstruction, down draught or restricted fresh air supply into the room.

If the problem cannot be put right the appliance must be disconnected and expert advice sought.

TEST: WHERE NO FAN IS PRESENT

Close all outside doors, doors and windows in the room in which the appliance is fitted.

Light the fire front only and run on heat setting 3. After 5 minutes apply a spillage test as shown in diagram 4.8.

If spillage occurs, leave fire front alight for up to a further 10 minutes and repeat test. Turn the fire front off.

Next light the back boiler unit only. Run on maximum, after 10 minutes apply spillage test as shown diagram 4.8.

If spillage occurs, leave the boiler alight for up to a further 5 minutes and repeat tests.

Leave the boiler alight.

Now light the fire front. Run on heat setting 3, after 10 minutes apply spillage tests as shown in diagram 4.9.

If spillage occurs leave the boiler and fire front alight for up to a further 5 minutes and repeat the tests.

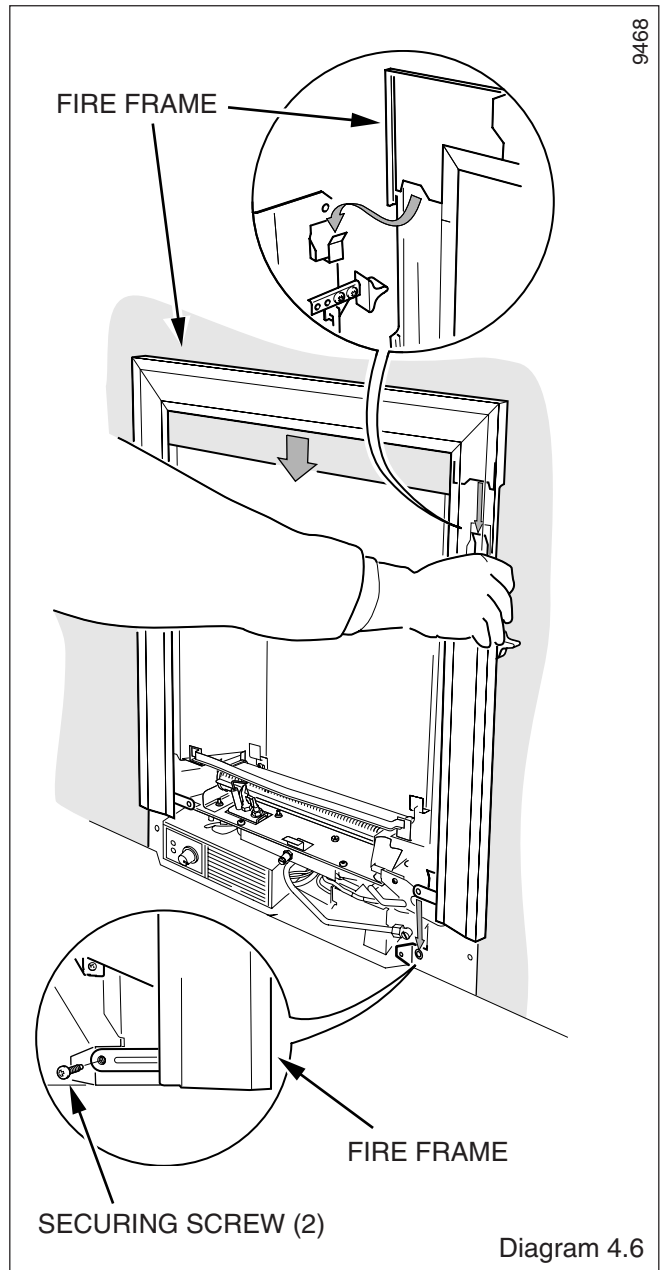

TEST: WHERE A FAN IS PRESENT

A fan means an extract fan or a fan for other open flued appliances or a circulating fan for a warm air unit, (whether or not gas fired). With the fan switched off carry out the appropriate spillage test with all doors and windows closed, as above.

If the above spillage test is satisfactory proceed as follows:

Open all doors connecting the room containing the appliance and the room in which the fan is fitted. Close all other doors and windows in the premises.

If the fan is in the same room as the appliance, close all doors and windows in that room. Switch the fan on and repeat the spillage test as above.

In ALL cases, if spillage occurs the cause must be found and put right before the fire is left.

IF THE FAULT CANNOT BE PUT RIGHT, THE FIRE MUST BE DISCONNECTED AND EXPERT ADVICE SOUGHT.

4 Lighting, Testing and Fitting of Internal Parts

9457

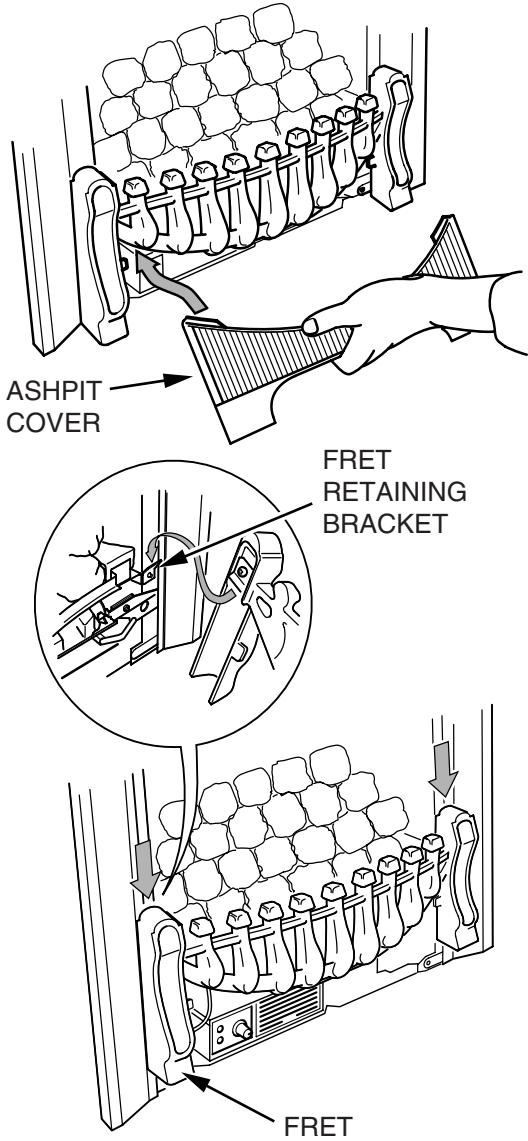

Chatsworth illustrated

Diagram 4.7

9051

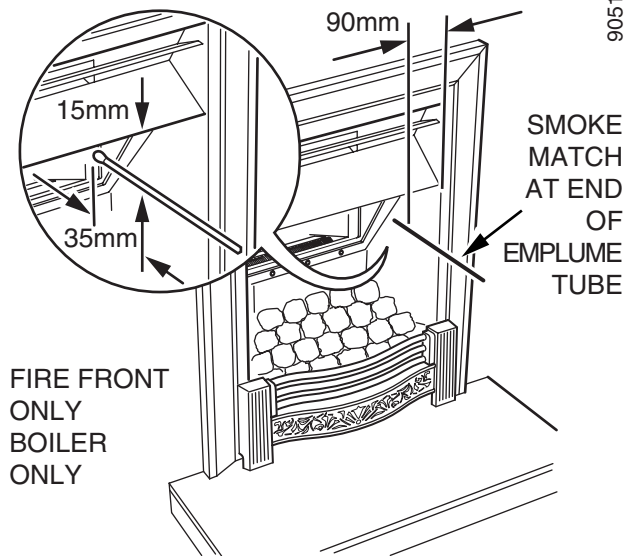

Diagram 4.8

9051

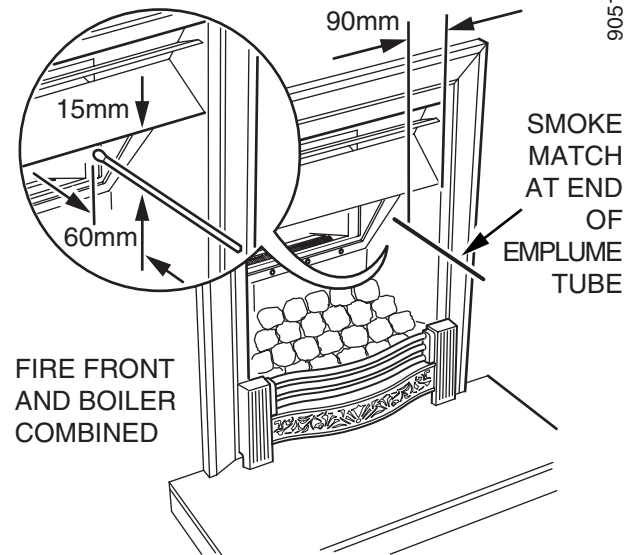

Diagram 4.9

5 Instructions to User

Hand the Instructions for Use, Installation & Servicing to the user and make sure that they are understood.

Refer to the Instructions for Use on how to light the fire.

Advise the customer that they should read their Users instructions before operating the fire and always follow the advice in the Section headed "Cleaning your Fire".

Advise that any smell which may be apparent on initial lighting is quite normal and it will quickly disappear.

Important. Advise that soft wall coverings, for example, blown vinyl wallpaper, are easily affected by heat, they may, therefore, scorch or become discoloured when close to a heating appliance. This should be borne in mind when having a heating appliance installed and when redecorating.

Advise that to ensure the continued efficient and safe operation of the fire it is recommended that it is checked and serviced at regular intervals. The frequency of servicing will depend upon the particular installation and usage, but in general once a year should be enough.

Advise that the chimney must be checked at least once a year and any debris found removed.

Draw attention, if applicable, to the current issue of the Gas Safety (Installation and Use) Regulations, 35, which imposes a duty of care on all persons who let out any property containing a gas appliance.

It is the Law that any servicing must be carried out by a competent person.

Reminder - Leave these instructions and the "Benchmark" logbook with the user.

6 Servicing

REMEMBER, When replacing a part on this appliance, use only spare parts that you can be assured conform to the safety and performance specification that we require. Do not use reconditioned or copy parts that have not been clearly authorised by Hepworth Heating Lt

6.1 Notes

To ensure the continued efficient and safe operation of the fire it is recommended that it is checked and serviced at regular intervals. The frequency of servicing will depend upon the particular installation and usage, but in general once a year should be enough.

It is the Law that any servicing is carried out by a competent person.

Refer to Section 1.

Before starting make sure that the gas supply is turned off at the gas fire supply cock, see diagram 6.1.

Make sure that the fire is cold before doing any servicing.

After servicing of parts always test for gas soundness with a suitable leak detection fluid.

WARNING. Take care as the burner has a naked flame.

To test the gas control assembly apply leak detection fluid to all joints, light the burner and check all joint for leakage at all settings.

Carry out functional check of controls.

After removing or disconnecting any pipework always make sure that it is refitted correctly and does not interfere with the fitting of the fire.

Unless stated otherwise all parts are replaced in the reverse order to removal.

6.2 Fret and Ashpit Cover

Remove fret and ashpit cover, see diagram 4.7.

Take care not to damage the frame.

Turn the gas supply off at the fire front service cock, see diagram 6.1.

6.3 Fuel Bed Supports and Fuel Effect Pieces

Following steps 1 to 8 in reverse order, remove the fuel effect pieces and fuel effect supports, see diagram 6 in Instructions for Use section.

Care should be taken as they become fragile with use.

Clean the fuel effect pieces and the fuel effect supports with a soft brush.

IMPORTANT: A VACUUM CLEANER MUST NOT BE USED ON FUEL EFFECT PIECES OR FUEL EFFECT SUPPORTS.

With the fuel effect pieces and fuel effect supports removed, the **base of the appliance may be cleaned with a vacuum cleaner.**

NOTE: The importance of positioning the fuel effect pieces correctly cannot be overemphasised if sooting is to be avoided. The flame effect may also be impaired and the life of the fuel effect pieces reduced if assembly directions are not followed, see section 4.3.

6 Servicing

6.4 Burner and Injector

The burner can be cleaned, using a suitable soft brush or vacuum cleaner.

Do not use a brush with wire bristles.

Disconnect the gas supply at the fire front gas service cock.

Remove the frame and fire front from the wall, refer to relevant parts of Sections 4.3, 4.2, 3.2 and 3.1.

With the fire front removed lay it on its back. Remove the three wires from the spark generator, see diagram 8.1.

Remove the shouldered securing screw, the burner securing screws pull out the burner assembly, see diagram 6.1.

Disconnect the gas supply pipe union nut from the injector and slacken the connection at the gas control valve, pull the pipe off the injector, see diagram 6.2.

Remove the injector.

Do not clean the hole with a wire or sharp instrument.

6.5 Flue Blockage Safety Device

Refer to Section 1.1.

When cleaning make sure that all the holes in the safety device are clear of dust and lint.

If damaged replace the safety device as Section 8.10.

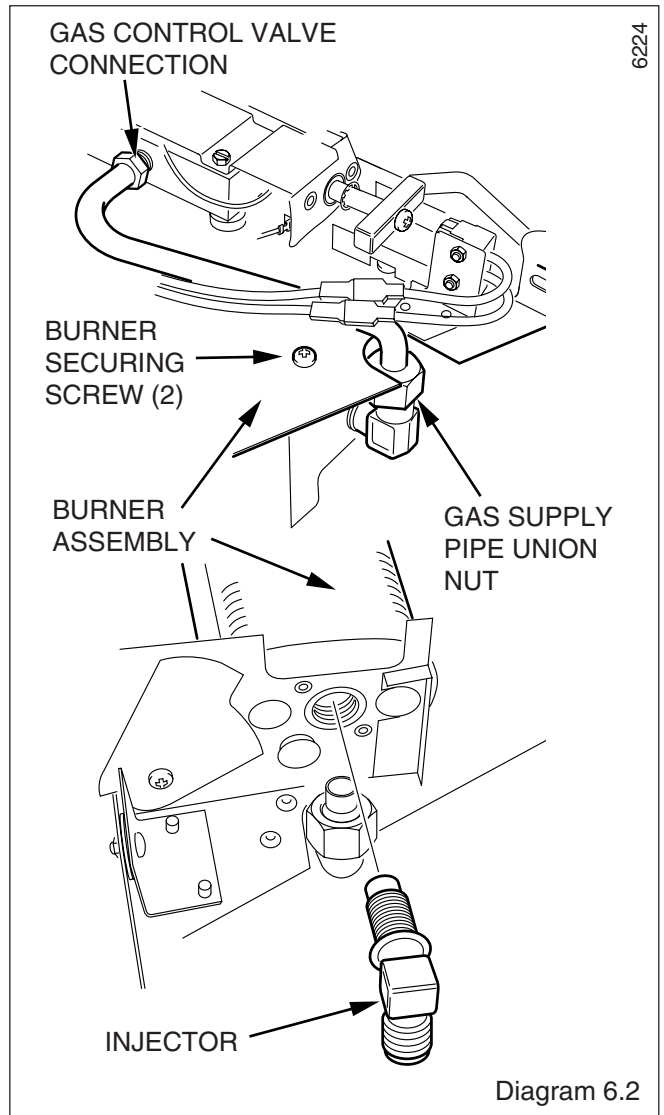

6224

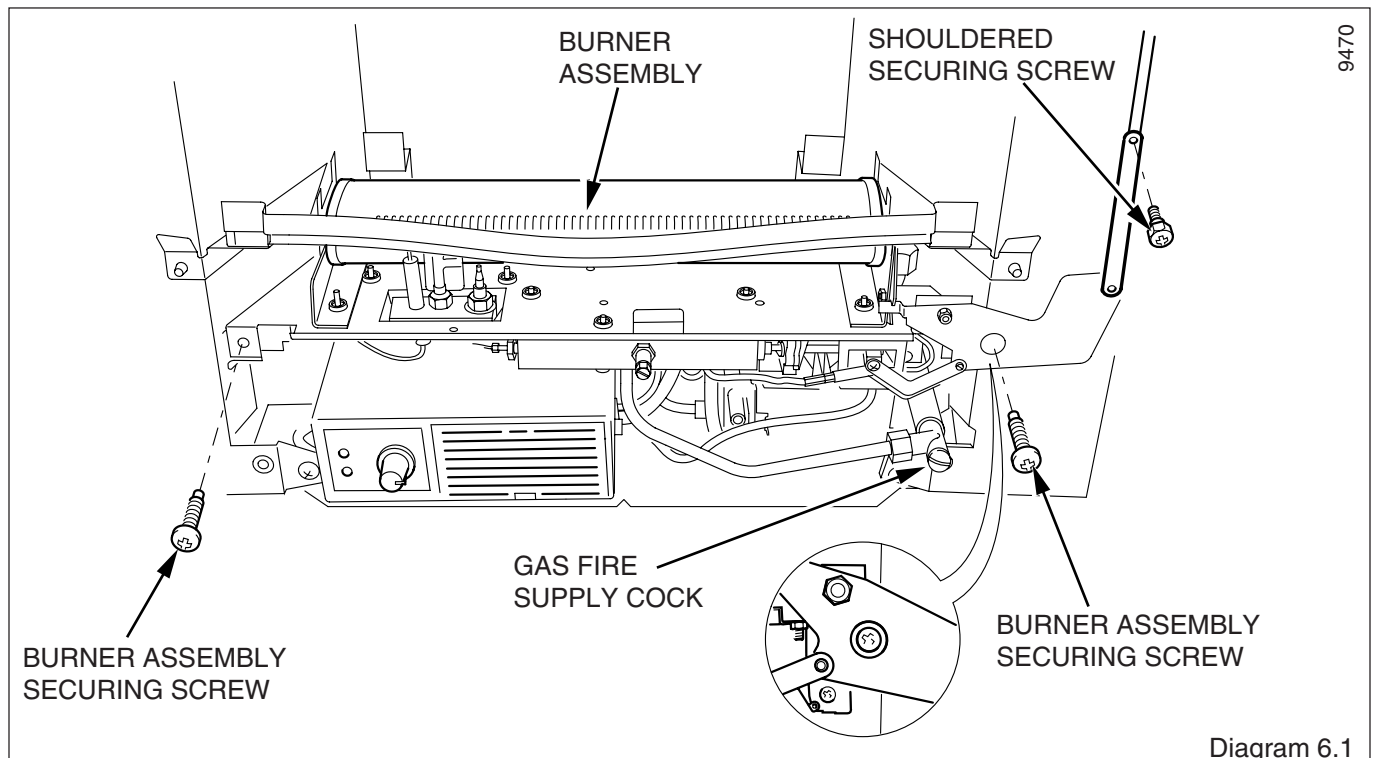

9470

6 Servicing

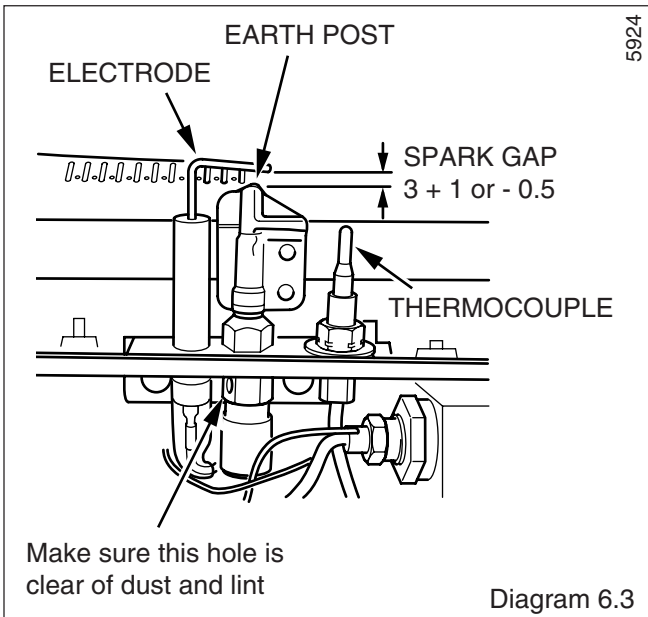

Diagram 6.3

6.6 Electrode

Ensure that the electrode is in line with the earth post and that the spark gap is as shown in diagram 6.3.

If damaged replace the safety device as Section 8.10.

6.7 Thermocouple

Inspect the thermocouple for wear and damage, clean with a soft brush, see diagram 6.3.

If damaged replace the safety device as Section 8.10.

When replacing the burner assembly, refer to diagram 6.4 (Locating burner support tabs).

6.8 Ignition Lead

Inspect the ignition lead for wear and damage, replace if necessary.

NOTE: When replacing the burner refer to diagram 6.4 (Locating the burner support tabs).

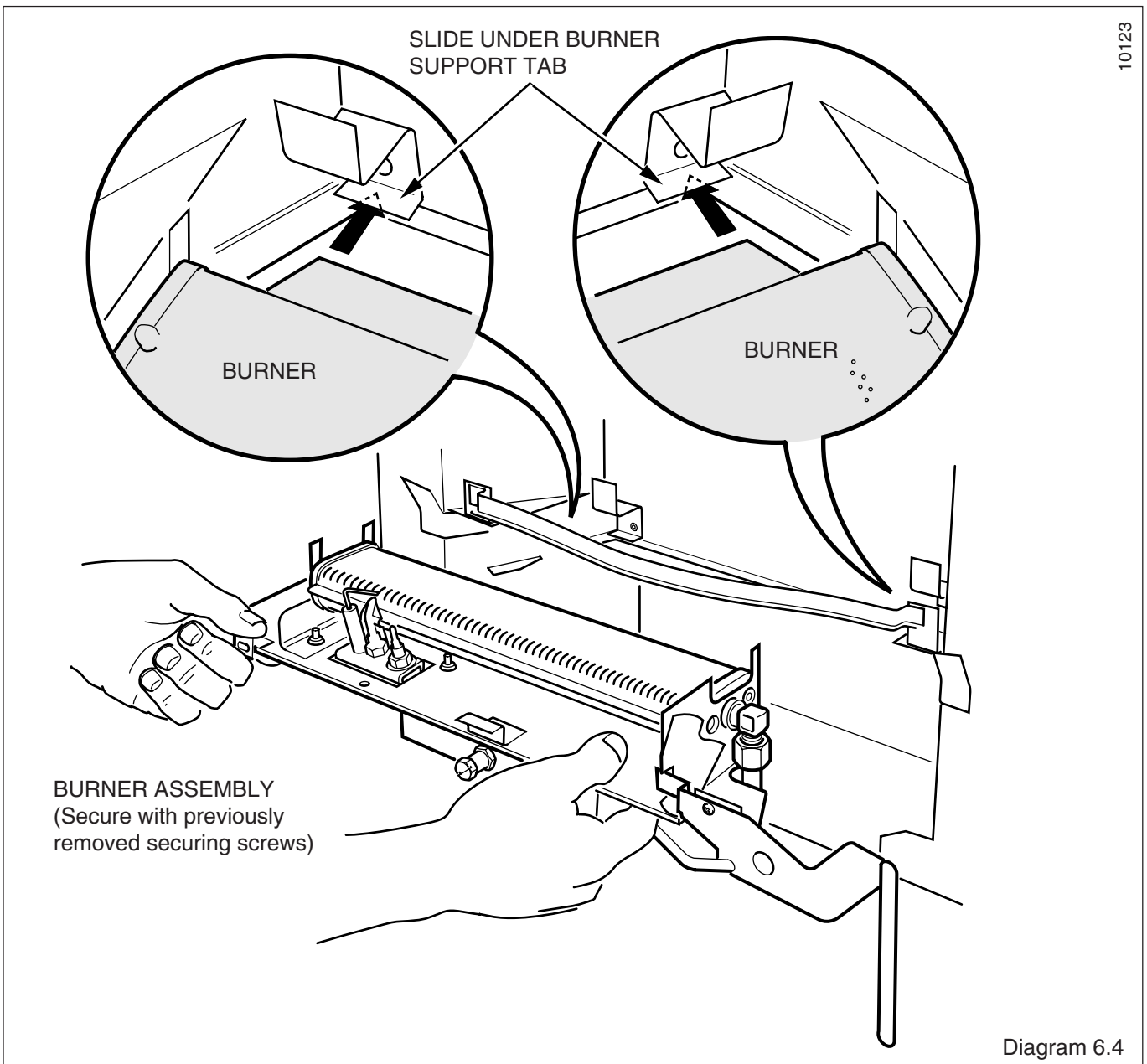

Diagram 6.4

7 Fault Finding

7.1 Fire Ignition

Refer to Fire Ignition Sequence of Operations, see diagram 7.1.

7.2 Safety Device

If the fire shuts down for no apparent reason the flue/chimney and the air inlets into the room must be checked.

Any problems found must be put right, before the fire is used again.

Also, check for dust and lint around the holes in the safety device.

IN ALL cases the room must be ventilated before attempting to relight the fire.

The safety device must not be bypassed or put out of action.

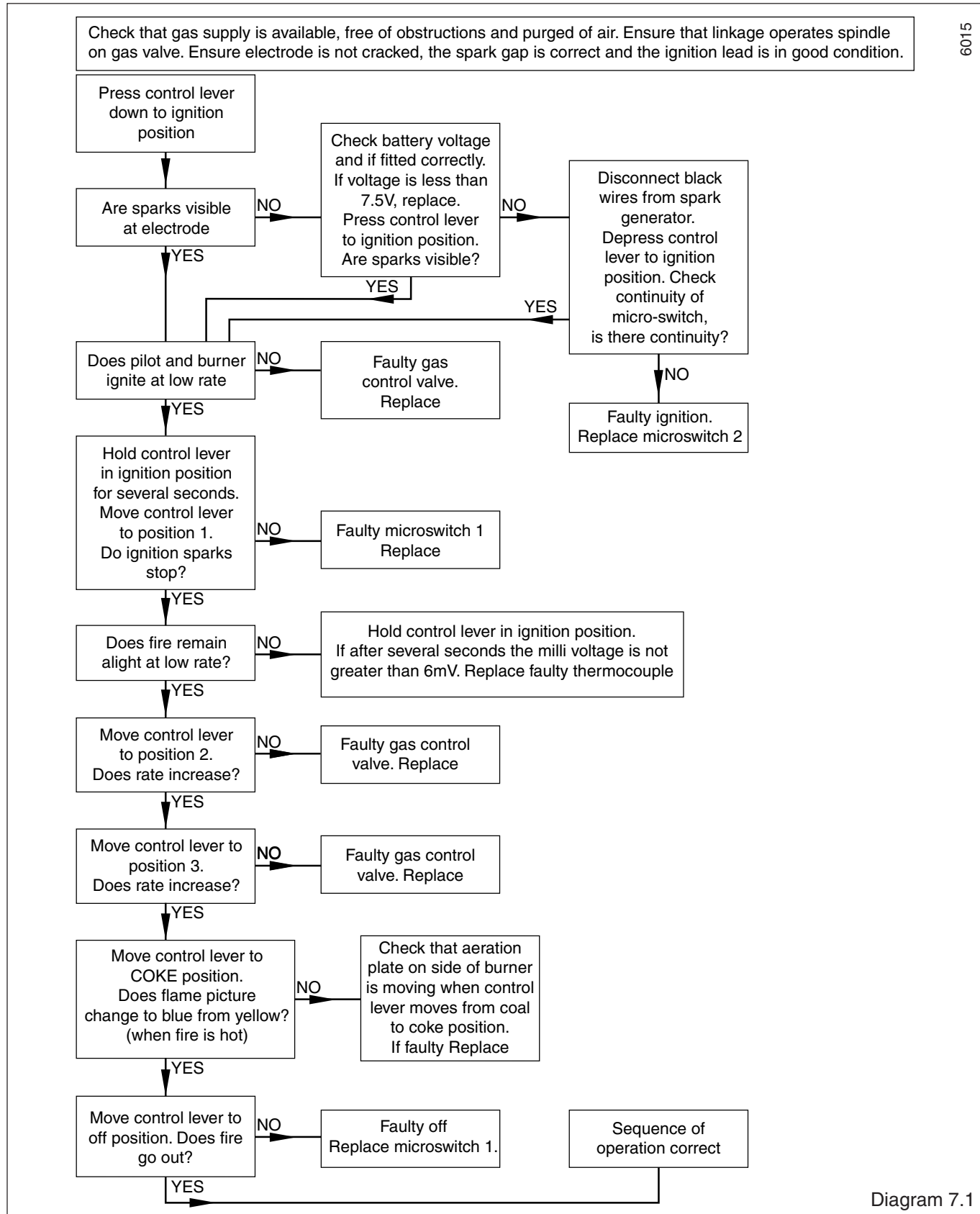

Diagram 7.1

8 Replacement of Parts

For the replacement of parts it is advisable in most cases to remove the fire front from the back boiler unit. Refer to relevant parts of Sections 4.3, 4.2, 3.2 and 3.1 for removal.

Notes:

Refer to Section 1.

Make sure that the fire front is cold before replacing any parts.

Replacement of parts must be done by a competent person.

Isolate the gas supply to the fire front, see diagram 6.1.

After replacing or disconnecting any gas carrying part, always test for gas soundness, using a suitable leak detection fluid and carry out functional check of controls.

To test the gas control assembly apply leak detection fluid to all joints, light the burner and check all the joints for leakage at all tap settings.

After removing or disconnecting any pipework always make sure that it is refitted correctly and does not interfere with the fitting of the fire front.

Unless stated otherwise reassembly of all parts is in the reverse order to removal.

8.1 Fret and Ashpit Cover

Remove the fret and ashpit cover, see diagram 4.7.

Take care not to damage the frame.

Turn the gas supply off at the fire front gas service cock, see diagram 6.1.

8.2 Fuel effect pieces and fuel bed supports

Refer to Section 4.3 and follow steps 8 to 1 to remove the fuel effect pieces and fuel bed supports, see diagram 6, in Instructions for Use.

8.3 Frame

To remove refer to diagram 4.6.

8.4 Burner Assembly

Remove the fire front from the back boiler unit.

Follow the instructions in Section 6.4 to remove the burner assembly.

To remove the burner disconnect the injector in Section 6.4, then remove the burner securing screws, this will release the burner.

8.5 Injector

Follow the relevant instructions in Section 6.4 to remove the injector.

8.6 Spark Generator

Remove the fire front from the back boiler unit.

Carefully lay the fire front on its back.

Disconnect the ignition lead and black cables, remove the securing screws, see diagram 8.1.

When reconnecting, the polarity of the connection from the generator to the microswitch is not important.

8.7 Battery

Remove the fret see diagram 4.7.

Take care not to damage the frame.

The battery is 9V and we recommend that it is of the alkaline type, bought locally.

When fitting make sure that it is connected as shown in diagram 4.3.

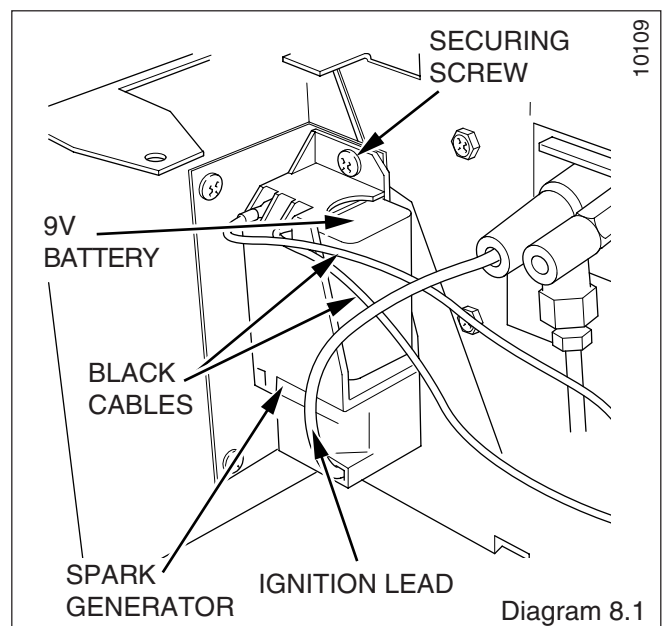

8 Replacement of Parts

8.8 Microswitch 1 and 2

Remove the fire front from the back boiler unit.

Follow instructions in Section 6.4 to remove the burner assembly.

To remove Microswitch 1, see diagram 8.2.

Remove the securing screws, nuts and electrical leads.

To remove Microswitch 2, see diagrams 8.1 and 8.2.

Remove the spark generator, diagram 8.1.

Remove the gas tap fitting block, diagram 8.2.

Remove the three securing screws to release the gas control valve, diagram 8.2.

Remove the circlip, diagram 8.2.

Disconnect the black cables from the microswitch, diagram 8.2.

Remove the microswitch, diagram 8.2.

When re-assembling make sure to refit the spacers between the gas control and burner assembly.

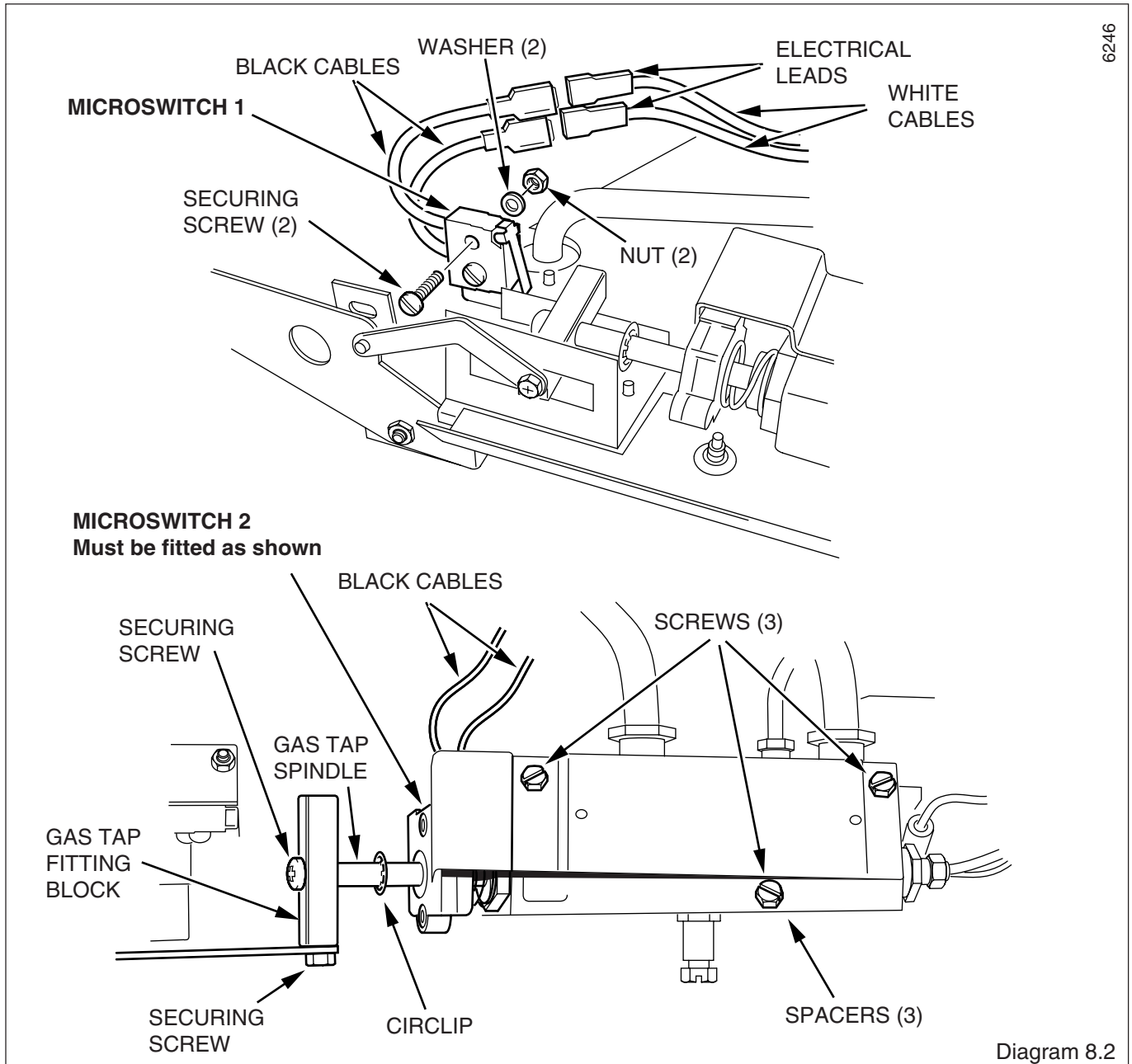

6246

8 Replacement of Parts

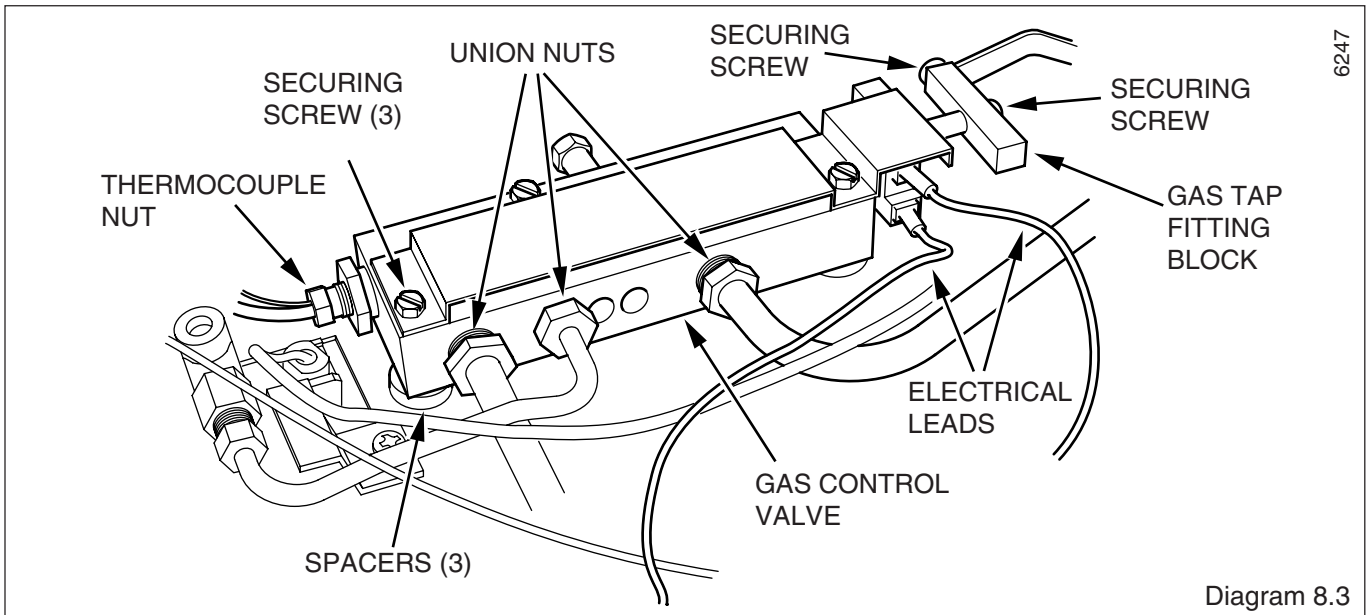

8.9 Gas Control Valve

Remove the fire front from the back boiler unit.

Follow instructions in Section 6.4 to remove the burner assembly

Remove the gas control valve, disconnecting the union nuts, thermocouple nut, gas tap fitting block, electrical leads and gas control valve securing screws, this will release the gas control valve, see diagram 8.3.

Remove the microswitch 2, see relevant parts of Section 8.8.

When re-assembling make sure to refit the spacers between the gas control valve and burner assembly.

8.10 Safety Device

Refer to Section 1.

Remove the fire front from the back boiler unit.

Follow instructions in Section 6.4 to remove the burner assembly

Refer to diagram 8.4, disconnect:

- the ignition lead
- the pilot pipe union at the safety device
- the thermocouple nut at the gas control valve
- the electrical connections
- the safety device bracket
- the safety device

8.11 Ignition Lead

Follow relevant parts of section 8.6.

Disconnect the ignition lead at the electrode and spark generator, refer to diagrams 8.1 and 8.4.

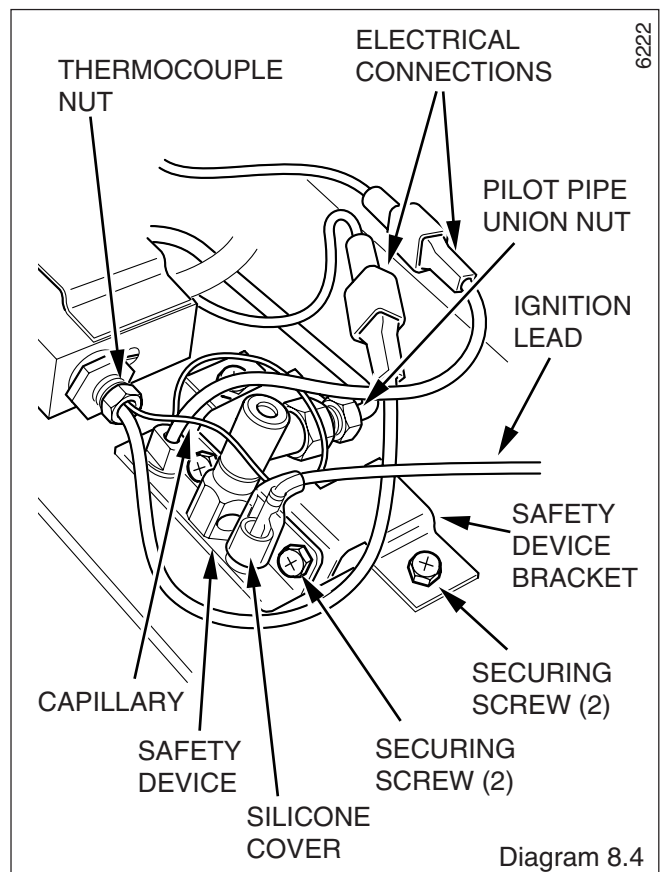

9 Spare Parts

When spare parts are required use only genuine Glow-worm parts and buy them from a recognised supplier.

Use only the fuel effect approved for this fire front.

Do not use more fuel effect pieces than shown.

Please quote the name of the fire front "Dovedale" or "Chatsworth".

If ordering from British Gas also quote the GC number of the fire from the data label and the GC number of the spare part, from the list.

Key No	Part No	Description	G.C. No.
1	210269	Rear support	E04764
2	210268	Middle support	E04765
3	210272	Fuel effect pieces (small)	E04767
4	210273	Fuel effect pieces (large)	E04769
5	210270	Side support L/H	E04770
6	210271	Side support R/H	E04768
7	210267	Front support	E11725
8	202179	Spark Generator	378351
9	230502	Gas control valve assy	*****
10	205739	Injector - Bray Cat 82-500	E04735
11	203443	Flue blockage safety device - SIT Ref: 9409	E04758
12	202275	Microswitch 1	E04761
13	800886	Microswitch 2	E04747
14	WX5500	Ignition lead	278467
15	209310P	Silver Badge (Black Chatsworth)	E04772
15	209311P	Brass Badge (Black Chatsworth)	E04773
16	800895	Gas tap spindle Circlip	E04748
17	212308	Fire Front Flue Seal	*****

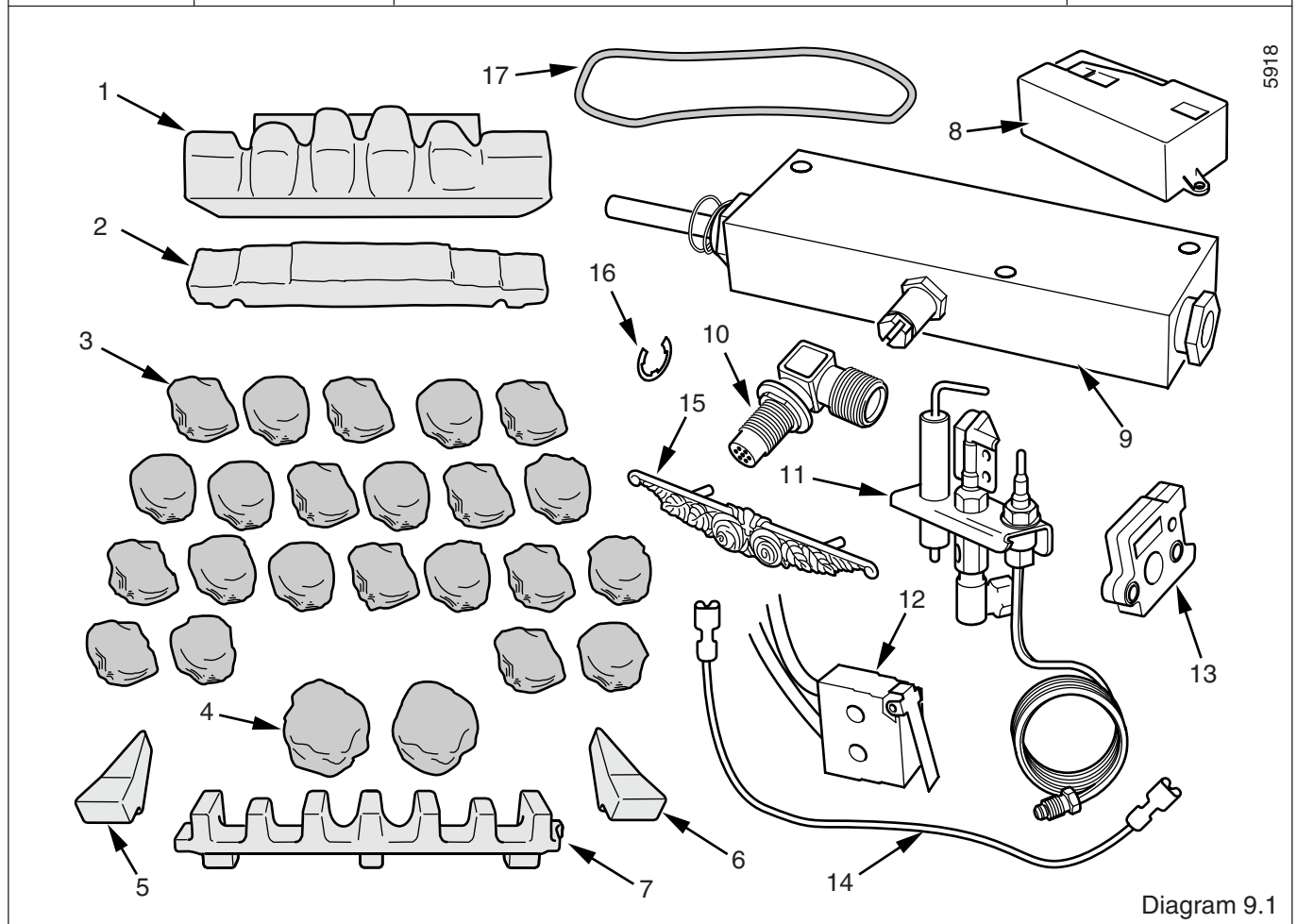

Because of our constant endeavour for improvement details may vary slightly from those in the instructions.