

559521

POTTERTON

INSTALLATION AND SERVICE INSTRUCTIONS

Gas Council Appliance No.47.590.08.

FOR USE WITH NATURAL GAS ONLY.

Lynx 2

Wall mounted, Fanned, Room sealed Combination Boiler

These instructions are to be followed and the specification of the appliance must not be modified.

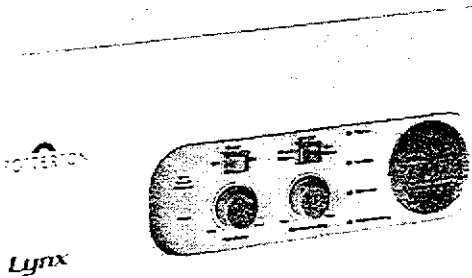

INSTALLATION AND SERVICE INSTRUCTIONS

LEAVE THESE INSTRUCTIONS ADJACENT TO THE GAS METER.

INDEX

	Page No.
General Data	2
Introduction	3
Installation Instructions	
1. General Info/Health and Safety	4
2. Location of Boiler	5
3-4. Flue Information/Air Supply	6
5. Guide to System Requirements	7
6. Methods of Filling	8
7. Installation to an Existing Heating System	8
8. Hard Water areas	8
9. Pump Performance Curve	9
10. Electrical Supply	9
11. Clearance around the appliance	10
12. Physical Dimensions	11
Boiler Installation	
1. Unpacking	12
2-4. Gas/Water Connections	13
5. Pressure Relief Valve	14
6. Wiring the Appliance	14
7. Boiler Wiring Diagram	14
Commissioning	
Initial Lighting	15
Gas Pressure Adjustment	17
Handing over to the User	18
Routine Maintenance	20
Component Replacement	
1. C.H. Overheat thermostat	21
2. D.H.W Overheat thermostat	21
3. Sensor and Ignition Electrode	21
4. Sensor and Ignition Lead	21
5. Burner	22
6. Injector	22
7-10. Gas Control Valve (SIT & Honeywell)	23
11. Case Seal	25
12. C.H Mode, On/Off Switches	25
13. Electronic Control	25
14. Air Pressure Switch	26
15. Fan	26
16. Fan Outlet Seal	26
17. Temperature Sensor D.H.W & C.H.	26
18. Pressure Gauge	26
19. Water Flow Switch C.H.	27
20. Water Flow Switch D.H.W.	27
21. Pump	27
22-23. Diverter Valve	27
24. Expansion Vessel D.H.W.	28
25. Expansion Vessel C.H.	29
26. Heat Exchanger	29
27. Auto Air Vent	30
28. Pressure Relief Valve	30
29. Water Pressure Switch	30
30. Transformer Assembly	30
31. Slight Glass and Securing frame	30
Functional Flow Diagram	31
Pictorial Schematic Wiring Diagram	32
Logic Sequence	33
Fault Finding Chart	34
Short Parts List	Back Page

Table 1. GENERAL DATA

Heat Input	Max.	29.31 kW	(100,000 Btu/h)
	Min.	12.3 kW	(42,000 Btu/h)
Heat Output	Max.	23.45 kW	(80,000 Btu/h)
		Modulating to	
	Min.	8.8 kW	(30,000 Btu/h)
Gas Rate	Full Ignition	2.73 cu.m/hr	96 cu.ft/hr
		0.98 cu.m/hr	34.6 cu.ft/hr
Inlet Pressure		20 mbar	8 in' w.g
Burner Pressure			
	Maximum (Max. setting on Gas Valve)	13.4 mbar	5.4 in wg
	Minimum (Electronically set)	1.6 mbar	0.64 in wg
	Ignition (Min. setting on Gas Valve)	1.0 mbar	0.4 in wg
Main Burner		Furigas 126,500,036.	
Gas Control Valve.	SIT Controls.	Nova 827. (0.827.123) inc. Modulator- 28V.DC. 0.007.413.	
	or Honeywell.	VR4605 M2067. inc. Modulator- V7335A 2224	
Burner Injector		BRAY Cat 23 2300 (4.3mm dia.)	
Electrical Supply		240V	~ 50 Hz;
Fuse Ratings.	External	3A	
	Internal	T2A	
Dry Weight		50 kg	(110 lbs)
Water Content C.H.		0.908 litres	(1.6 pints)
	D.H.W.	0.516 litres	(0.9 pints)
Gas Supply Connection		1/2" B.S.P.F. Gas Cock	
Inlet Connection D.H.W.		15 mm compression Isolating Valve	
Outlet Connection D.H.W.		15 mm copper pipe	
Flow Connection C.H.		22 mm compression Isolating Valve	
Return Connection C.H.		22 mm compression Isolating Valve	
Safety Discharge Pipe		15 mm copper pipe	
C.H. Sealed System			
	Maximum Operating Pressure	2.5 bar	36.3 lb/in2.
	Minimum Operating Pressure	0.5 bar	7.25 lb/in2 .
	10 litre expansion vessel. Pre-charge Pressure	0.5 bar	7.25 lb/in2.
Central Heating Flow Temperature		Max. Load 85 Deg. C	
		Min. Load 90 Deg. C	
Central Heating Return Temperature		74 Deg.C (Nominal)	
D.H.W. Minimum Operating Flow Rate		2.5 l/min (0.55 gals/min)	
D.H.W. Flow rate 35 Deg. C Rise		9.6 l/m (2.11 gals/min)	
D.H.W. Flow rate 45 Deg. C Rise		7.5 l/m (1.65 gals/min)	
D.H.W. Temperature Max.		65 Degrees.C	
	Min.	35 Degrees.C	
D.H.W. Max. Pressure		10 bar	145 p.s.i.
D.H.W. Min. Operating Pressure (Dynamic)		0.8 bar	11.6 p.s.i.
D.H.W. Expansion Vessel. Pre-charge Pressure		3.5 bar	50.8 p.s.i.

INTRODUCTION

The Potterton "Lynx 2" is a fully automatic, wall mounted, fan assisted, room sealed, combination boiler, designed to operate on Natural Gas only.

It adjusts automatically to provide central heating outputs between 8.8 kW (30,000 Btu/h) and 23.45 kW (80,000 BTU/h) depending on the system requirements. Domestic hot water has priority over the central heating system and is generated instantaneously within the appliance at a maximum output of 23.45 kW (80,000 Btu/h).

This type of combination appliance has the advantage that tanks and copper cylinders are not required. A range of 4 flue systems with small terminals, makes siting and installation easy.

The combination boiler is designed for use with a fully pumped sealed system only.

It is supplied fully tested and assembled with a circulating pump, diverter valve, pressure gauge, pressure relief valve, and expansion vessels. Fig. 1 shows the main components of the boiler assembly.

The appliance has two completely separate heating systems embedded into a copper heat exchanger. Both systems are completely independent. A mode switch controls the choice

of service between central heating and hot water only. The boiler water flow system is shown in Fig.2.

With the mode switch set to CH Off and the boiler switch set to On, the combination boiler fires only when the domestic hot water is drawn off.

With the mode switch set to CH Timed the boiler will operate the central heating for the time periods set on the optional internal or externally mounted clocks.

If CH24 Hours is selected the boiler will operate continuously. The central heating is supplied at a pre-set temperature determined by the central heating thermostat setting.

If domestic hot water is drawn off while the central heating is running the combination boiler will automatically transfer the boiler heat output to the domestic hot water supply.

At the minimum D.H.W. draw-off rate of 2.5 litres/m the maximum temperature is limited to 65 deg Celcius by the modulating gas control.

The combination boiler has a white casing which can be removed for servicing; the boiler code badge can be seen below the control panel. The control panel can then be hinged sideways on its pivot for accessibility. This will expose the data plate which is on the rear of the control panel cover.

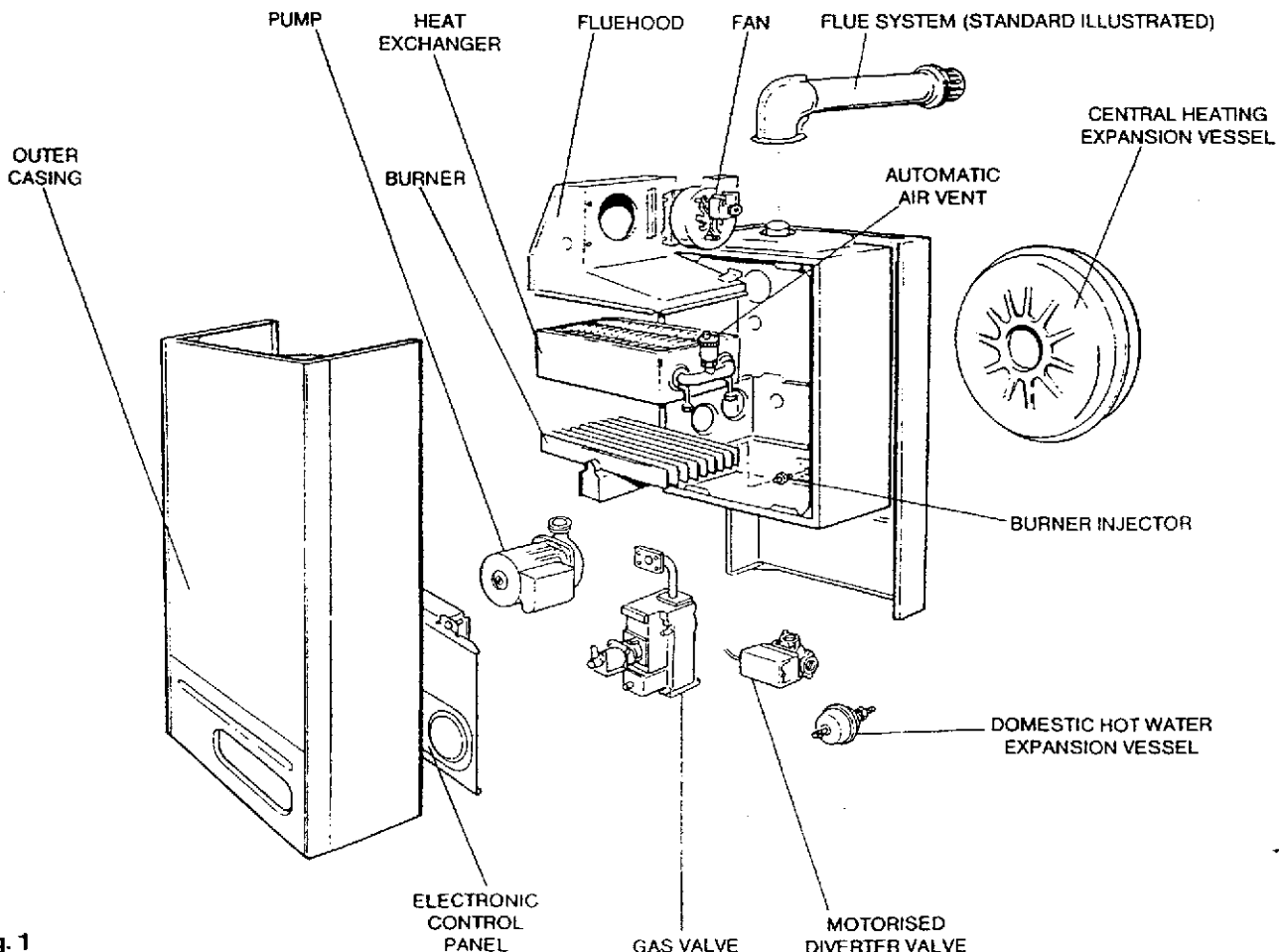

Fig. 1

Installation Instructions

GAS SAFETY (INSTALLATION AND USE) REGULATIONS 1984.

The appliance must be installed and serviced by a competent person, in accordance with the above Regulations.

In the UK 'Corgi' Registered Installers (including the Regions of British Gas) undertake the work to a safe and satisfactory standard.

Failure to install appliances correctly could lead to prosecution.

It is in your own interest, and that of safety, to ensure that the Regulations are complied with.

1. GENERAL INFORMATION

Both the user and the manufacturer rely heavily on the installer, whose job it is to install the combination boiler, and connect it to a correctly designed heating system. Acquaint yourself with the British Standards concerning installation requirements. If you need advice on any points your Potterton Myson Service Operations would be pleased to help (see rear page). It is recommended that tools suitable for brass fittings are used, and have a capability to accommodate hexagon sizes up to 50mm.

CODES OF PRACTICE

I.E.E Regulations

Model Water Bye Laws

Building Regulations/Building Standards for Scotland. Health and Safety Document No.635. (The Electricity at Work Regulations 1989)

- BS. 6891 Installation of low pressure pipes.
BS. 6798 Installation of gas boilers of rated input not exceeding 60kW.
BS. 5449: Forced circulation hot water CH systems. Including smallbore and microbore domestic central heating systems.
BS. 5546 Installation of gas hot water supplies for domestic purposes.
BS. 5440:1 Flues (for gas appliances of rated input not exceeding 60 kW).
BS. 5440:2 Air supply (for gas appliances of rated input not exceeding 60 kW).
BG. DM2 Guide for gas installation in timber framed buildings.

NOTE:

A type sample of the Lynx 2 Combination Boiler has been tested and examined by British Gas, and is certified to comply with the relevant requirements of BS 5258 Part 15 1990, BS 6332 Part 1 1983 (and the relevant B.G./S.B.G.I. agreements). It is therefore important that no external control devices e.g. flue dampers, economisers etc, be directly connected to this appliance unless covered by these installation and service instructions or otherwise recommended by Potterton Myson Limited in writing. If in doubt please enquire.

Any direct connection of a control device not recommended by Potterton Myson could invalidate the B.G. certificate and the normal appliance warranty and could also infringe the Gas Safety Regulations.

Manufacturers instructions must NOT be taken in any way as over-riding statutory obligations.

GAS SUPPLY

The local Gas Region should be consulted, at the installation planning stage, in order to establish the availability of an adequate supply of gas.

An existing service pipe must NOT be used without prior consultation with the Local Gas Region.

A gas meter can only be connected by the Local Gas Region, or by a Local Gas Region Contractor.

An existing meter should be checked, preferably by the Gas Region, to ensure the meter is adequate to deal with the rate of gas supply required.

Installation pipes should be fitted in accordance with BS 6891.

Pipework from the meter to the combination boiler must be of an adequate size.

Do NOT use pipes of a smaller size than the combination boiler inlet gas connection (15mm).

The complete installation must be tested for gas soundness and purged as described in BS 6891.

HEALTH AND SAFETY INFORMATION FOR THE INSTALLER AND SERVICE ENGINEER

Under the Consumer Protection Act 1987 and Section 6 of the Health and Safety at Work Act 1974, we are required to provide information on substances hazardous to health.

Small quantities of adhesives and sealants used in the product are cured and present no known hazards.

The following substances are also present.

INSULATION AND SEALS

Material - Ceramic Fibre. Alumino - Silicone Fibre.

Description - Boards, Ropes, Gaskets.

Known Hazards - Some people can suffer reddening and itching of the skin. Fibre entry into the eye will cause foreign body irritation. Irritation to respiratory tract.

Precautions - People with a history of skin complaints may be particularly susceptible to irritation. High dust levels are only likely to arise following harsh abrasion.

In general, normal handling and use will not present discomfort, follow good hygiene practices, wash hands before consuming food, drinking or using the toilet.

First Aid - Medical attention must be sought following eye contact or prolonged reddening of the skin.

HEAT EXCHANGER

Material - Copper with lead/tin coating.

Description - Finned copper tube.

Known Hazards - Inhalation or ingestion of lead dust or fumes may cause headache and nausea.

Precautions - Unused heat exchangers present minimal risk to health other than normal hygiene practices would demand regarding washing before eating etc. Deposits found on or below a heat exchanger that has been in use could contain lead oxide. Avoid inhalation by using a vacuum cleaner in conjunction with other cleaning tools when servicing the appliance.

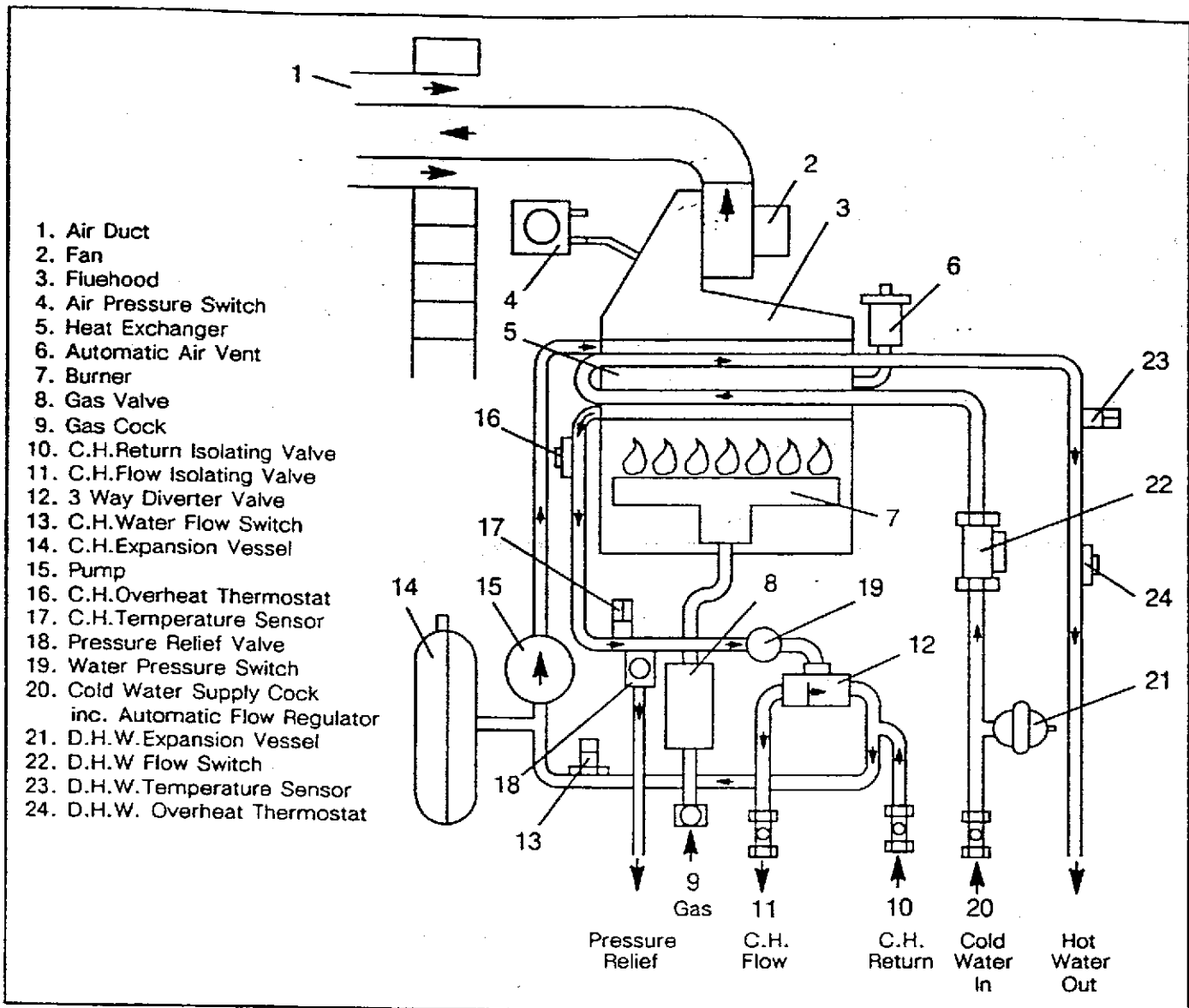

Fig. 2 BOILER FLOW DIAGRAM

2. LOCATION OF BOILER

In siting the combination boiler, the following limitations, **MUST** be observed:

- a) The position selected for installation should be within the building, unless otherwise protected by a suitable enclosure. It must allow adequate space for installation, servicing and air circulation around the appliance.
- b) This position **MUST** also allow the chosen flue termination to be made correctly. The boiler must be installed on a flat vertical wall which is capable of supporting the weight of the combination boiler, and any ancillary equipment.

The appliance may be installed on a combustible wall, subject to the requirements of the Local Authorities and Building Regulations.

IMPORTANT NOTICE

If the combination boiler is to be fitted in a timber framed building it should be fitted in accordance with the British Gas publication 'Guide for Gas Installations in Timber Frame Housing'. (Reference DM2). If in

doubt advice must be sought from the Local Gas Region of British Gas.

The combination boiler may be installed in any room or internal space, although particular attention is drawn to the requirements of the current I.E.E. Wiring Regulations, and in Scotland, the electrical provisions of the Building Regulations applicable in Scotland, with respect to the installation of the combination boiler in a room or internal space containing a bath or shower.

Where a room-sealed appliance is installed in a room containing a bath or shower, any electrical switch or appliance control, utilising mains electricity should be so situated that it cannot be touched by a person using the bath or shower.

A compartment used to enclose the combination boiler **MUST** be designed and constructed specifically for this purpose. An existing cupboard, or compartment, may be used provided it is modified accordingly.

Where installation will be in an unusual location, special procedures may be necessary. BS 6798 gives detailed guidance on this aspect.

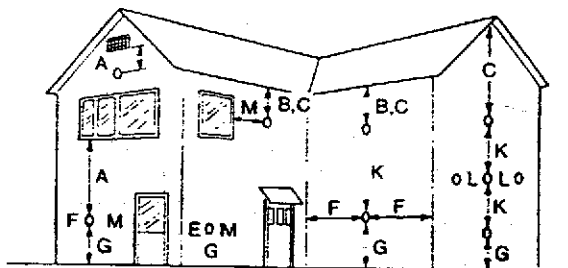

a) HORIZONTAL FLUES

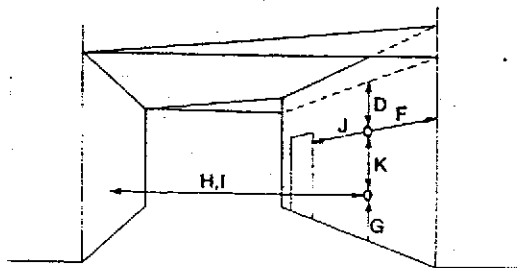

b) BELOW CARPORT

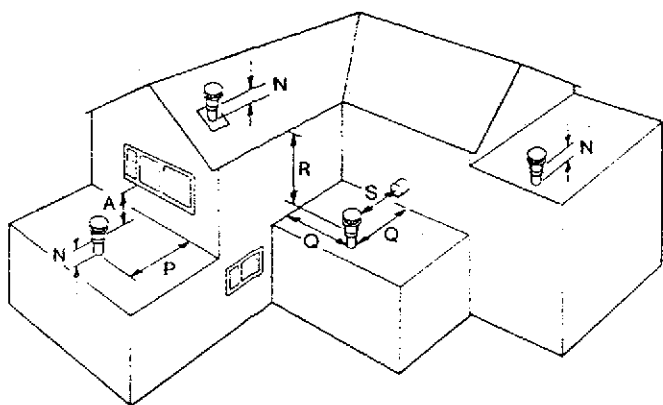

c) VERTICAL FLUES

Fig. 3 FLUE TERMINATIONS

POSITION	MIN. DISTANCE mm
A DIRECTLY BELOW AN OPENABLE WINDOW, AIR VENT, OR ANY OTHER VENTILATION OPENING	300
B BELOW GUTTER, DRAIN/SOIL PIPE	75
C BELOW EAVES	200
D BELOW A BALCONY/CARPORT ROOF	200
E FROM VERTICAL DRAIN PIPES AND SOIL PIPES	75
F FROM INTERNAL OR EXTERNAL CORNERS	300
G ABOVE ADJACENT GROUND OR BALCONY LEVEL	300
H FROM A SURFACE FACING THE TERMINAL	600
I FACING TERMINALS	1,200
J FROM OPENING (DOOR/WINDOW) IN CARPORT INTO DWELLING	1,200
K VERTICALLY FROM A TERMINAL ON THE SAME WALL	1,500
L HORIZONTALLY FROM A TERMINAL ON THE SAME WALL	300
M ADJACENT TO OPENING	150
N ABOVE ROOF LEVEL	250
P FROM ADJACENT WALL TO FLUE	210
Q FROM INTERNAL CORNER TO FLUE	230
R BELOW EAVES OR BALCONY	600
S FROM FACING TERMINAL	1,200

3. FLUE TERMINAL AND DUCTING (Fig: 3)

The maximum standard flue duct length is 740mm measured from the boiler outlet to the outside face of the wall. This is suitable for a maximum wall thickness of 508mm, and a minimum wall thickness of 76mm, at both side and rear. The flue can be set horizontally, at any angle to the combination boiler, through 360 degrees, to a miniature terminal on the outside of the building. If the distance from the flue outlet to the outside wall is greater than 740mm, a 3m extension kit is available (Part No 222014). The siting of the flue terminal on the outside wall of the building is shown in Figs. 3a & 3b.

Two Vertical flue kits are also available suitable for flue lengths of up to 2.6m (Part No. 222015) and 4m (Part No.222016) to terminate through a roof. The siting of the terminal through a roof is shown in Fig 3c.

Only the above flue systems should be used with the Lynx 2 Combination boiler

If the flue terminates less than 2m above a balcony, ground level, or above a flat roof to which people have access, then a suitable terminal guard must be fitted. A terminal guard is available (Part No. 205792).

NOTE:

Where a flue terminal is installed less than 1 metre from a plastic, or painted gutter, or 500mm from painted eaves, an aluminium shield 1 metre long, should be fitted to the underside of the gutter or painted surface. A suitable wall plate should be fitted to the painted wall surface of a mobile home.

IMPORTANT

It is absolutely ESSENTIAL, to ensure that products of combustion discharging from the terminal cannot re-enter the building, or any other adjacent building, through ventilators, windows, doors, natural air infiltration, or forced ventilation/air conditioning. If products of combustion are found to be re-entering any building, the appliance MUST be turned OFF IMMEDIATELY.

4. AIR SUPPLY (See Table 2)

Detailed recommendations for air supply are given in BS 5440:2. The following notes are intended for general guidance:

It is not necessary to have a purpose provided air vent in the room or internal space in which the combination boiler is installed.

If the combination boiler is to be installed in a cupboard or compartment, permanent air vents are required (for cooling purposes) in the cupboard/compartment, at both high and low levels.

The air vents must either communicate with a room/or be direct to outside air.

Position of air vent	Air from room/ internal space	Air direct from outside
High Level	264 cm ² 40 in ²	132 cm ² 20 in ²
Low Level	264 cm ² 40 in ²	132 cm ² 20 in ²

Table 2. AIR SUPPLY

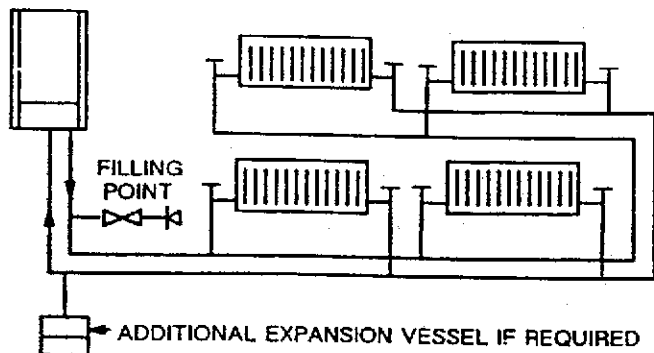

Fig. 4 TYPICAL SEALED SYSTEM

5. GUIDE TO SYSTEM REQUIREMENTS (Figs.4 & 8)

The combination boiler is specifically designed for sealed systems only. Therefore the central heating system should be in accordance with the relevant recommendations given in BS 6798 and also, smallbore and microbore systems BS 5449 Part 1.

The boiler does not require a by-pass for heat dissipation purposes, but the boiler will only operate if the central heating flow rate exceeds 8 l/min (1.8 gal/min). In systems which are fitted with Thermostatic Radiator Valves on all radiators, it may be beneficial to include a valved by-pass if the boiler is required to operate when only one or two radiators are to be heated. In these situations the by-pass should be adjusted to the point where there is just sufficient water flow to operate the boiler, when all the radiator valves are closed.

The boiler thermostat and pump overrun system will then operate and close the boiler down.

The installation should be designed to work with flow temperatures of up to 90 degrees Celcius. All components of the system must be suitable for a maximum pressure of 3 bar (45 psi) and a temperature of 110 degrees Celcius. The following components are incorporated within the appliance.

- Circulating pump.
- Diverter valve.
- Pressure Relief valve with a non-adjustable pre-set lift pressure of 3 bar (45 psi).
- Pressure gauge covering the range 0-4 bar (0-60 psi).
- 10 litre expansion vessel with initial charge pressure of 0.5 bar (7 psi).
- Water flow switch's (C.H. and D.H.W.)

The domestic hot water system must be in accordance with the relevant recommendations of BS 5546. Copper tubing to BS 2871:1 is recommended for water carrying pipework and MUST be used for pipework carrying potable water. All capillary joints in the DHW pipework must be joined with a lead free solder.

Ancillary pipework, not forming part of the useful heating surface, should be lagged to prevent heat loss and any possible freezing, particularly where pipes run through roof spaces and ventilated under-floor spaces.

If the capacity of the central heating system should exceed 120 litres, an additional vessel should be installed on the return to the combination boiler from the heating system (Fig. 4). Guidance on vessel sizing is given in Table 3.

To allow the maximum expansion capacity available in the boiler the pre-charge pressure in the central heating expansion vessel must be equal to the initial system pressure at the appliance.

Safety valve setting (bar)	3.0		
Initial system pressure (bar)	0.5	1.0	1.5
Total water content of system	VESSEL VOLUME (L)		
litres			
25	2.1	2.7	3.9
50	4.2	5.4	7.8
75	6.3	8.2	11.7
100	8.3	10.9	15.6
125	10.4	13.6	19.5
150	12.5	16.3	23.4
175	14.6	19.1	27.3
200	16.7	21.8	31.2
225	18.7	24.5	35.1
250	20.8	27.2	39.0
275	22.9	30.0	42.9
300	25.0	32.7	46.8
325	27.0	35.7	50.7
350	29.1	38.1	54.6
375	31.2	40.9	58.5
400	33.3	43.6	62.4
425	35.4	46.3	66.3
450	37.5	49.0	70.2
475	39.6	51.8	74.1
500	41.6	54.5	78.0
For system volumes other than those given above, multiply the system volume by the factor across	0.0833	0.109	0.156

Table 3. EXPANSION VESSEL REQUIREMENTS

Deduct from the value given in the table the 10 litre expansion vessel supplied.

Draining taps should be at least 1/2 in BSP nominal size and be in accordance with BS 2879.

EXTERNAL CONTROLS

To obtain economical use of the appliance it is advisable to fit external controls. These controls can take the form of:-

- Time clock (an internal option is available Potterton Part No. 222019).
- Room thermostat
- Thermostatic radiator valve (TRV)
- Zone valves

The combination of all these controls can utilise the most effective and economical use of the heat generated by the boiler. It is advisable to control the temperature of the main living area with a room thermostat and other areas by TRV's. This arrangement will allow the most economical use of heat and will reduce heat loss from the distribution pipework during stand by periods when the room thermostat is satisfied.

6. MAINS WATER FEED: CENTRAL HEATING

A connection must be incorporated into the central heating system to facilitate filling. There must be no direct connection to the mains water supply, even through a non-return valve, without the approval of the Local Water Authority.

PERMISSIBLE METHODS OF FILLING

(1) DIRECT METHOD (Fig. 5)

A detachable flexible hose is connected to a stop valve fitted to an outlet on the service main. The other end of the hose is connected to a second stop valve and a double check valve. The double check valve is fitted to an inlet connection on the central heating return pipe under the appliance.

The hose should be disconnected after filling.

Where the mains pressure is excessive a pressure reducing valve shall be used to make filling easier.

The following fittings shall form a permanent part of the system and shall be fitted in the order stated.

- a) A stop valve complying with the requirements of BS 1010 Part 2, (the temporary hose from the draw off tap shall be connected to this fitting).
- b) Double check valve of an accepted type.

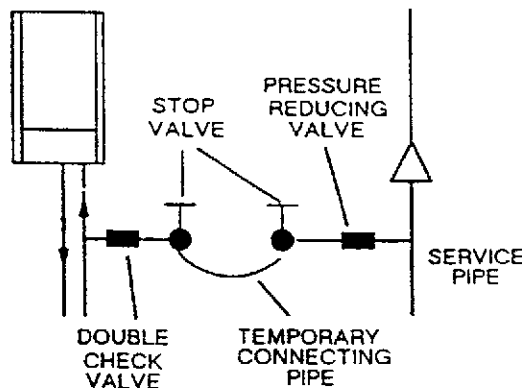

Fig. 5 MAINS TOPPING UP METHOD

(2) BOOSTER PUMP METHOD

The system may be filled through a self contained unit comprising a cistern, pressure booster pump and if necessary, an automatic pressure-reducing valve or flow restrictor.

The pressure booster pump must be capable of pressurising the system to a minimum of 0.8 bar (11.6 p.s.i.) measured at the appliance.

The cistern should be supplied through a temporary connection from a service pipe or cold water distributing pipe. The unit may remain permanently connected to the heating system to provide limited water make-up.

Provisions for make up water

Provision should be made for replacing water loss from the system by re-pressurisation of the system. See section on Methods of Filling.

Reference should be made to British Gas Publications "Material and Installation Specifications for Domestic Central Heating and Hot Water".

Note:

The Lynx 2 combination boiler is fitted with a three - way diverter valve manufactured by various companies. If the diverter valve on your boiler is fitted with a manual operation lever, it will ease initial filling of the system if the lever is temporarily moved to the 'man' (open) position during the filling operation. The valve will automatically reset when Central Heating is required.

7. INSTALLATION TO AN EXISTING CENTRAL HEATING SYSTEM

The combination boiler is designed to operate on a sealed system only, therefore if the existing system is of the open type it will have to be modified to comply with BS 6798.

If the existing system does not give a minimum flow rate of 8 litres/min, and a single radiator heat emittance is required, a suitable bypass will be necessary.

Before installing a new combination boiler to an existing system flush out the old system with a recommended descaling/flushing agent at least twice.

Also check pipework and renew any corroded pipework or fittings. Valve glands must be repacked or replaced wherever necessary and any defective controls replaced.

8. HARD WATER AREAS

If the area of installation is recognised as a hard water area, (above 200 p.p.m.) it is essential that a suitable water treatment device of an electronic, magnetic or galvanic type be installed in the mains water supply.

To assess water hardness, immerse the test strip supplied, for about one second in a water sample (NOT IN RUNNING WATER) so as to moisten all the zones.

Inspect the strip after 1-2 minutes, check the zones, if two or more zones have changed colour the hardness of the water is above 200 p.p.m. and a water treatment device will be required.

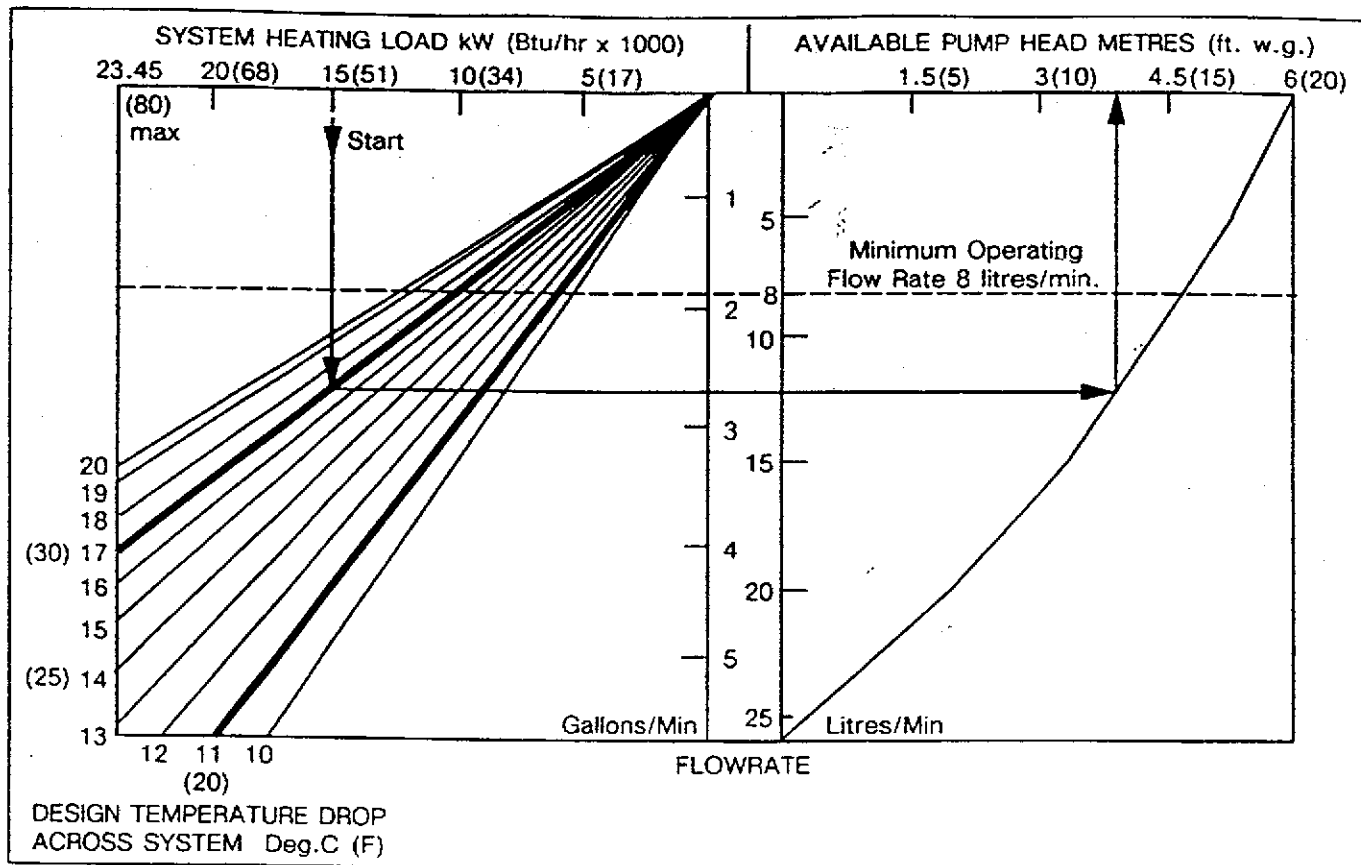

Fig. 8 PUMP PERFORMANCE CURVE / HYDRAULIC PRESSURE LOSS

9. PUMP PERFORMANCE CURVE

The circulating pump fitted within the appliance should be capable of satisfying most system requirements. Fig. 8 indicates the amount of pump head available for the system. The boiler resistance is already taken into account in this curve.

HOW TO USE FIG. 8.

Starting with the required SYSTEM HEATING LOAD, draw a vertical line downwards so that it intersects the chosen SYSTEM DESIGN TEMPERATURE DROP line, normally this would be 11 deg C (20 deg F) although up to 17 deg C (30 deg F) can be used without increasing radiator sizes. From this intersection point draw a horizontal line so that it intersects the PUMP CURVE. From this intersection draw a vertical line upwards.

The AVAILABLE PUMP HEAD can now be read from the horizontal scale, and the corresponding FLOW RATE from the vertical scale in the centre of the chart.

The system must be designed so that its hydraulic resistance does not exceed the available head unless an additional circulating pump is fitted. More available head can be achieved by choosing a greater temperature difference.

If the flow rate through the boiler is less than 8 l/min, then the burner will not ignite. This is to maintain maximum fuel economy. If flow rates of less than 8 l/min cannot be avoided then a system by-pass should be fitted.

10. ELECTRICAL SUPPLY (See Fig.9 & 10)

Wiring external to the appliance MUST be in accordance with the current I.E.E. Regulations for Electrical Installations, and any Local Regulations which apply. The combination boiler is supplied for 240 Volts ~ 50 Hz, Single Phase. To protect the appliance it is essential that the electrical supply is fused at 3 Amp rating.

**THIS APPLIANCE
MUST BE EARTHED**

The method of connection to the mains electricity supply must provide means of completely isolating the electrical supply to the combination boiler and its ancillary controls.

Preferably by the use of a fused three-pin plug and unswitched shuttered socket-outlet, both complying with the requirements of BS1363. See Fig. 19.

OR

A 3 Amp fused double-pole switch, having a 3mm contact separation on both poles, can be used. See Fig. 10.

It is important that the point of connection to the mains should be readily accessible and adjacent to the combination boiler.

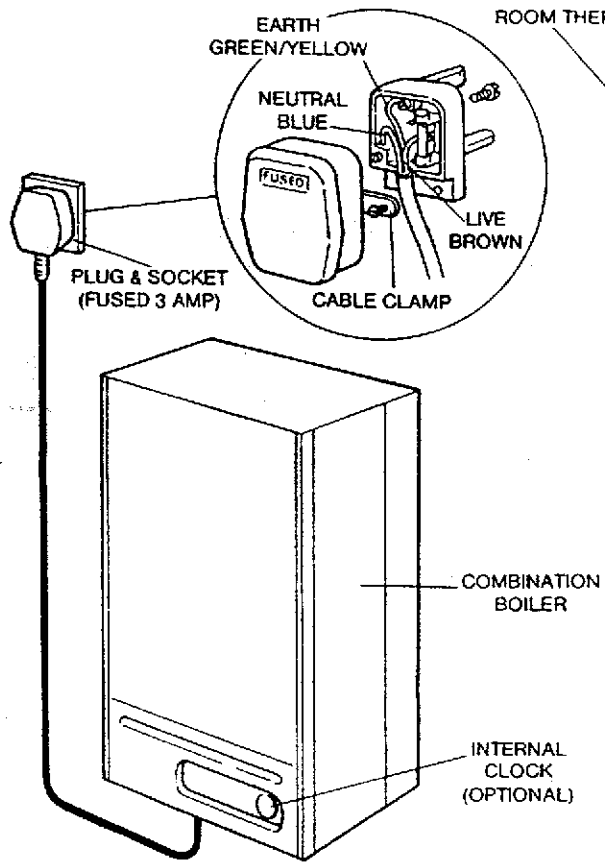

Fig. 9 BASIC WIRING ARRANGEMENT

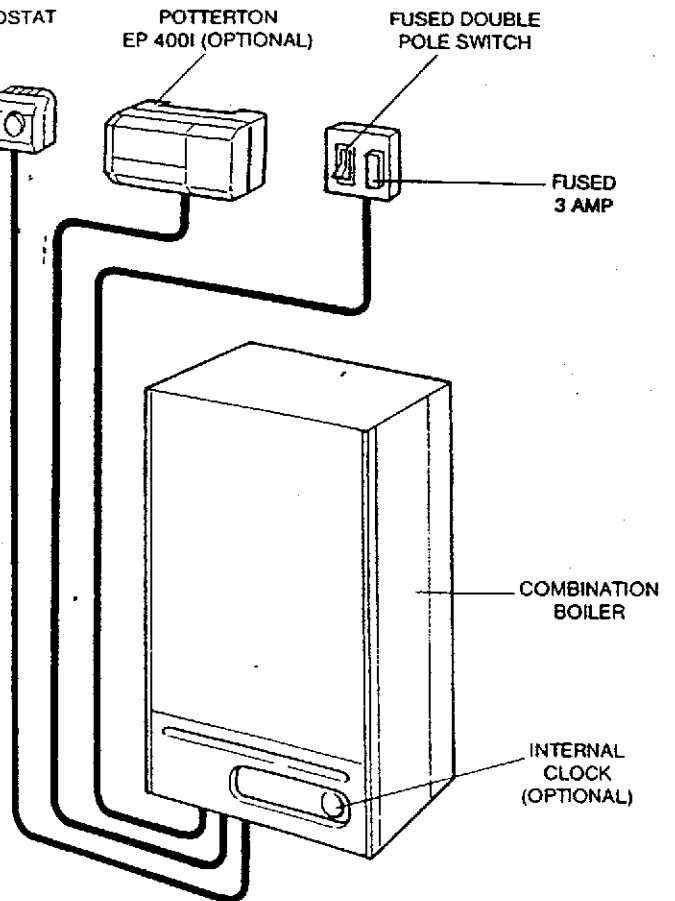
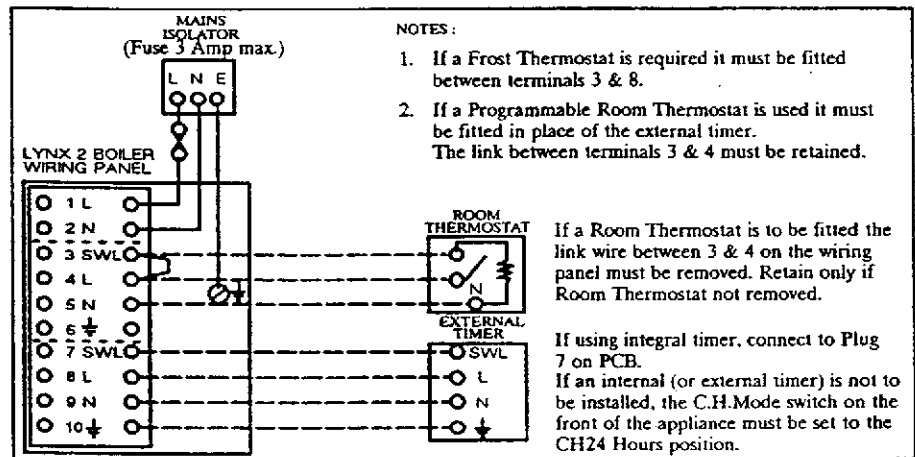

Fig. 10 RECOMMENDED ARRANGEMENT

Fig. 10a
CUSTOMER WIRING
(See Fig. 17)

WARNING
ALL EXTERNAL
CONTROLS
MUST BE WIRED
DIRECTLY TO THE
BOILER AS SHOWN.



NOTES:

1. If a Frost Thermostat is required it must be fitted between terminals 3 & 8.
2. If a Programmable Room Thermostat is used it must be fitted in place of the external timer. The link between terminals 3 & 4 must be retained.

If a Room Thermostat is to be fitted the link wire between 3 & 4 on the wiring panel must be removed. Retain only if Room Thermostat not removed.

If using integral timer, connect to Plug 7 on PCB.
If an internal (or external timer) is not to be installed, the C.H. Mode switch on the front of the appliance must be set to the CH24 Hours position.

11. CLEARANCES AROUND THE APPLIANCE (see Fig. 11)

Additional clearances than those given may be necessary for installation, as conditions vary from site to site it is left to the discretion of the installer.

The position selected for the appliance must provide the following minimum clearances which are necessary for operation and servicing, 5mm each side, 160mm at the top (300mm is preferred to allow removal of the central heating expansion vessel without removing the appliance from the wall) and 150mm between the bottom of the appliance and any surface.

A minimum of 500mm is required in front of the appliance for access during servicing.

For low level installations, or where the appliance is adjacent to a right hand wall, installation may be found easier if the gas and water pipes are pre-formed and fitted, before wall-mounting the combination boiler.

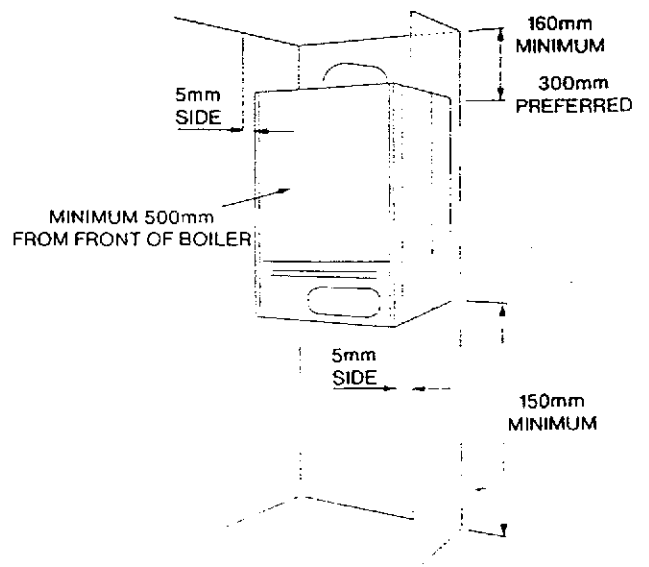
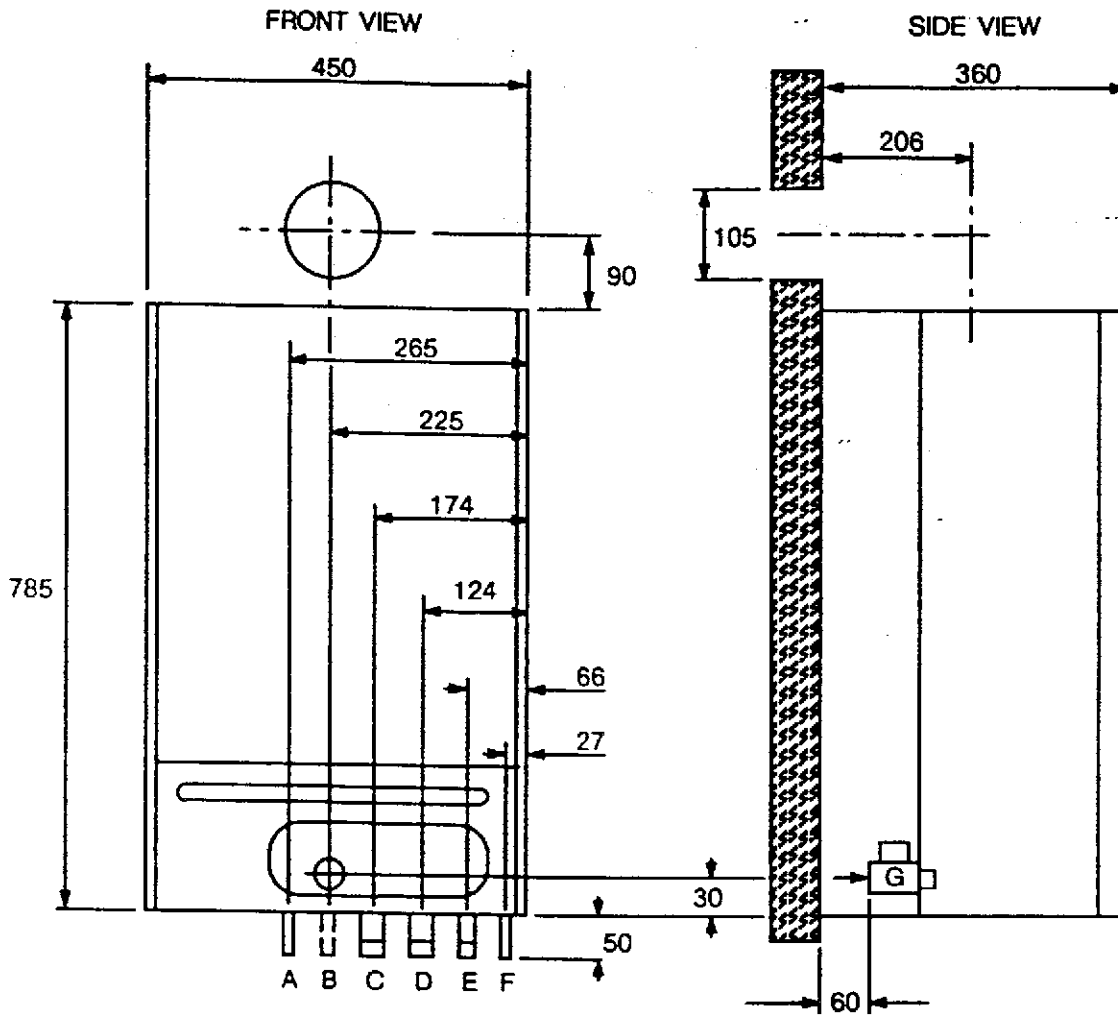

Fig. 11 CLEARANCES AROUND THE APPLIANCE

12. PHYSICAL DIMENSIONS



Note. Pipe B (Gas Supply) is not supplied and must be fitted by the installer.

- A. PRESSURE RELIEF PIPE
- B. GAS SUPPLY
- C. C.H.FLOW PIPE
- D. C.H RETURN PIPE
- E. COLD WATER SUPPLY
- F. DOMESTIC HOT WATER
- G. GAS COCK

BOILER INSTALLATION

It is **MOST IMPORTANT** that the appliance is installed in a **VERTICAL POSITION**, with the flue system passing through the wall or ceiling in a **Horizontal or Vertical plane**. A minor deviation from the horizontal is acceptable, provided that this results in a downward slope of the flue system away from the combination boiler.

Two adjustment pads located at the bottom of the combination boiler back panel, are provided to facilitate alignment (see Fig.12).

1. UNPACKING

Preparation

Note: Two removable support legs are fitted to the base of the boiler to protect the pipework, care must still be taken when handling the combination boiler to prevent damage to pipework situated at the base of the appliance (see Fig.13)

The appliance will arrive on site in two separate cardboard cartons.

(1). THE LARGE CARTON. The Boiler.

- Containing
- i) The Combination appliance fully assembled. Part No. 222010.
 - ii) The Installation/Serviceing and Users Instructions. Part No. 559356.
 - iii) The wall fixing template. Part No. 300209.

(2). THE SMALL CARTON. The Flue System.

There are 4 different types of flue system packs to suit your requirements which are supplied separately from the boiler. Installation instructions are included with each pack. Make sure you have the flue you require.

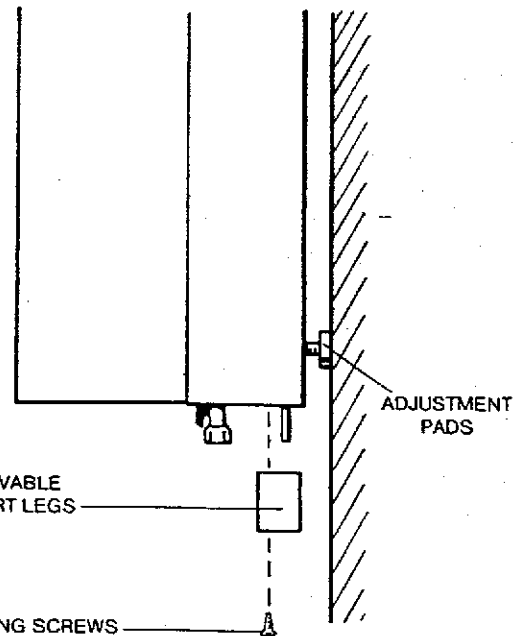

Fig. 12 BOILER ALIGNMENT

Flue Types:-

- i. Standard Horizontal Flue.
 - ii. 3m Horizontal
 - iii. 2.6m Vertical
 - iv. 4.0m Vertical
- a) Unpack the cartons and check the contents.
 - b) Remove the outer casing as follows; undo the securing screw at the base of the outer casing, pull the base of the casing forward approx 50mm and lift off the supporting top hooks. (See Fig. 13). Place the casing safely to one side. There is a transit packing piece of cardboard under the casing, this must be removed before installation.
 - c) At this point follow the Installation Instructions supplied with the FLUE SYSTEM PACK then proceed as follows:

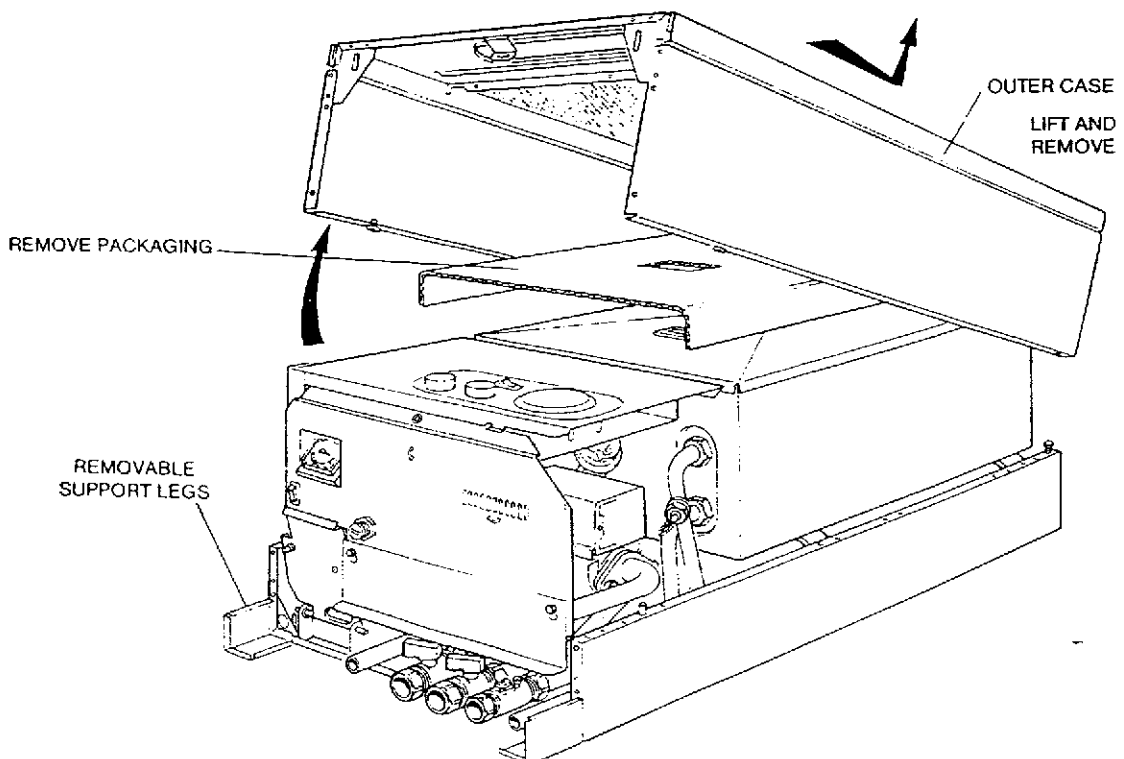

Fig. 13

2. GAS CONNECTION (see Fig.14)

A minimum gas pressure of 20 mbar (8 in w.g.) must be available at the combination boiler inlet at full flow rate, (see General Data).

Install a gas supply pipe (not less than 15mm diameter copper or 1/2" Iron) to the combination boiler and connect to the gas service cock situated at the bottom centre of the appliance. Connection is made in the horizontal plane and must run to the rear of the appliance and then downwards. Ensure the front of the pipe is not more than 65mm from the wall (otherwise the isolator cover panel will not fit).

3. D.H.W. SUPPLY

- a) The domestic hot water circuit does not need a pressure relief valve, but it is essential to ensure that the pressure of the cold water supply does not exceed 10 bar, if in doubt it is advisable to install a pressure reducing valve. The minimum pressure needed to operate the domestic hot water system is 0.8 bar with a flow of approximately 2.5 litres per minute.
- b) Flush out all foreign matter from the supply pipe before connecting to the appliance.
- c) Connect the cold water supply to the 15mm isolating cock (labelled **Cold Water Supply**). Connect the hot water outlet pipe to the 15mm pipe labelled **DHW outlet** using a 15mm Compression fitting.

Note: The Cold Water Supply Isolating Cock incorporates an automatic flow limiting device and water strainer.

SHOWERS

If a shower control is to be supplied from a Lynx 2 Combination unit it should be of the type which incorporates a pressure balancing valve (i.e. MIRA 415 EQUAMATIC).

If the shower control is existing and is of a mechanical type, it may be necessary to fit a drop tight pressure reducing valve to the mains supply. Refer to the Shower Manufacturers instructions.

Note

Showers with a loose flexible hose may require the fitting of a double check valve, to comply with water Byelaw 17.

4. C.H. WATER CONNECTIONS (see Fig. 14)

- a) Before any central heating connections are made to the combination boiler, all system valves should be opened and the system thoroughly flushed out with cold water.
- b) Connect the central heating return pipe to the isolating cock marked **CH Return**.
- c) Connect the central heating flow pipe to the isolating cock marked **CH Flow**.

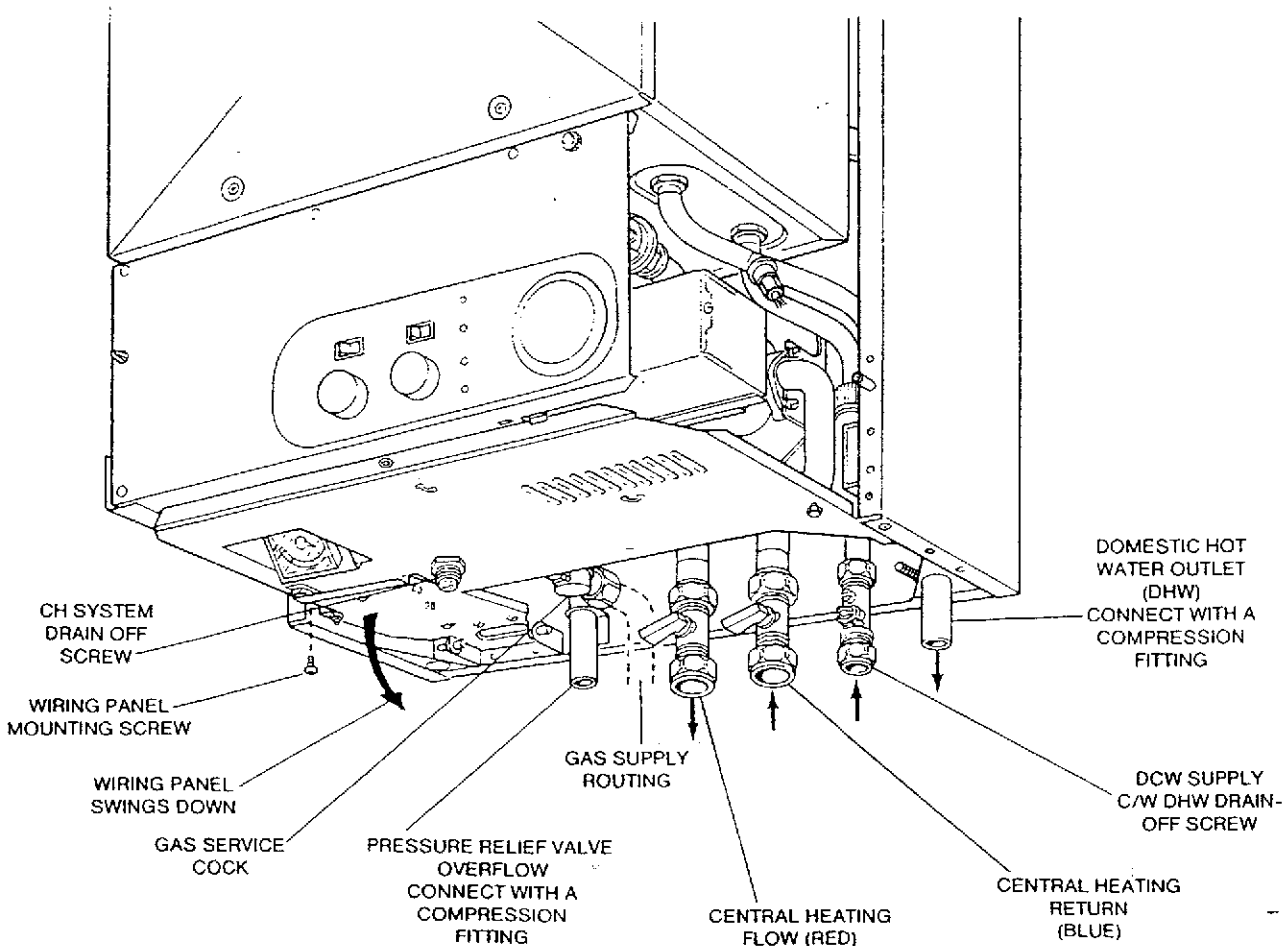

Fig. 14

5. PRESSURE RELIEF VALVE (Fig. 15)

The pressure relief valve is pre-set at 3 bar.

Install a pressure relief valve discharge pipe, not less than 15 mm O.D. and connect to the Pressure Relief outlet connection using a 15mm Compression fitting. It must discharge to the outside of the building, where possible over a drain. The discharge must be such that it will not be hazardous to occupants or cause damage to external electric components or wiring. The pipe should be fluted and directed towards THE WALL.

IT MUST NOT DISCHARGE ABOVE AN ENTRANCE, OR WINDOW, OR ANY TYPE OF PUBLIC ACCESS. THE INSTALLER MUST CONSIDER THAT THE OVER-FLOW COULD DISCHARGE BOILING WATER.

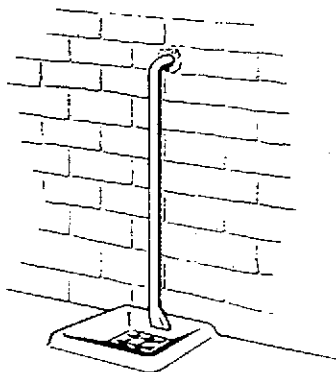

Fig. 15 PRESSURE VALVE DISCHARGE

6. WIRING THE APPLIANCE (See Fig. 16)

The internal wiring of the appliance is shown in Fig. 16. The wiring diagram is also on the inside of the casing wrap.

- Undo the single retaining screw on the underside of the wiring panel and allow the panel to swing open. See Fig. 14.
- Using PVC insulated cable of not less than 0.75 mm.sq. (24/0.2mm to BS 6500 Table 16), wire up the panel referring to the termination label. (See Fig. 17)

Note: Ensure that all cables pass through the wiring panel bush and are securely fixed by the cable clamp/s. If a room thermostat is to be fitted, remove the Red link wire between terminals 3 and 4 and discard.

- If the installation does not have an internal or external timer the C.H. Mode switch on the front of the appliance must be set to the CH 24 Hours position.

- Check all wiring and reposition wiring panel.

- Secure with screw provided.

Note: The electrical mains supply must be fused at 3 Amps, and the connection must be made to the wiring panel in such a way that should the lead disengage from the cable clamp, the current carrying conductors become taut before the earth conductor.

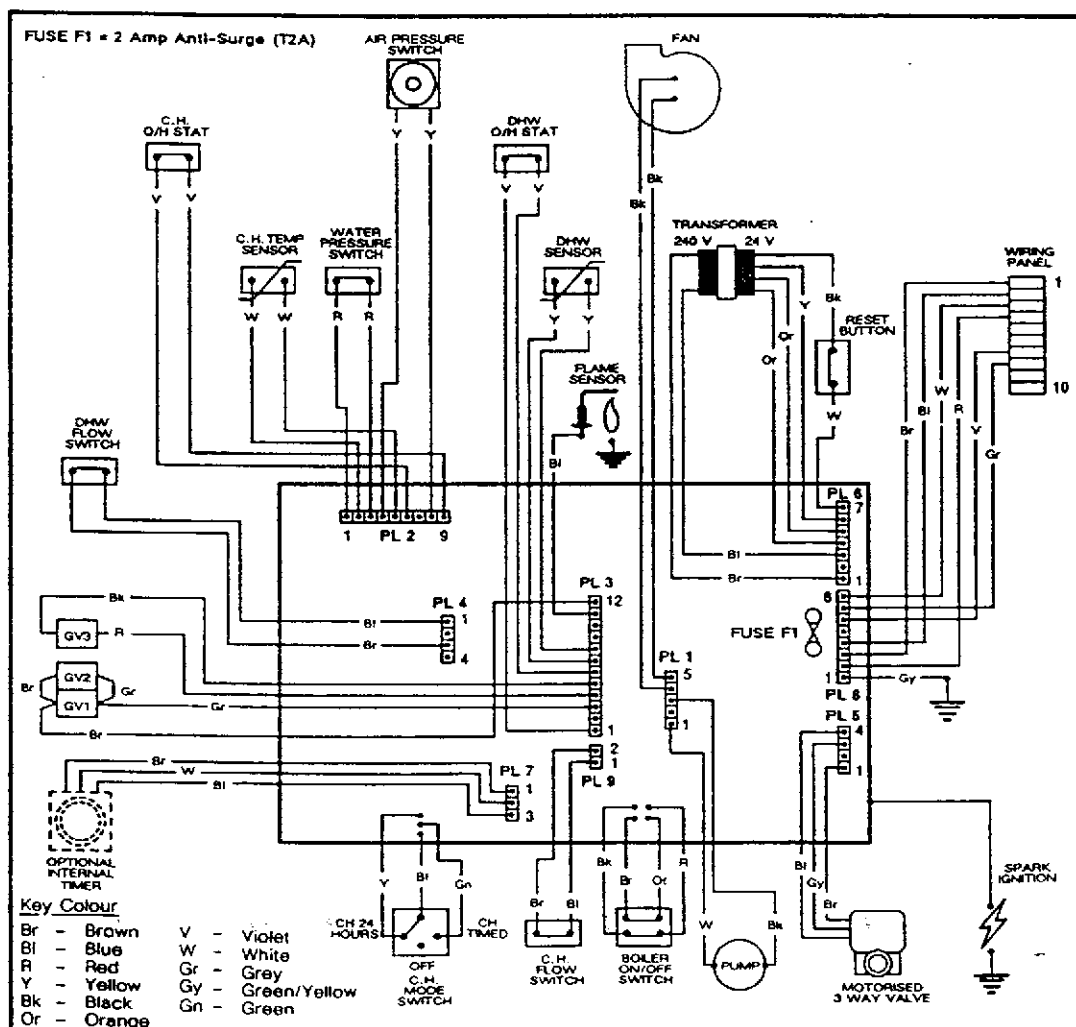

Fig. 16 BOILER WIRING DIAGRAM

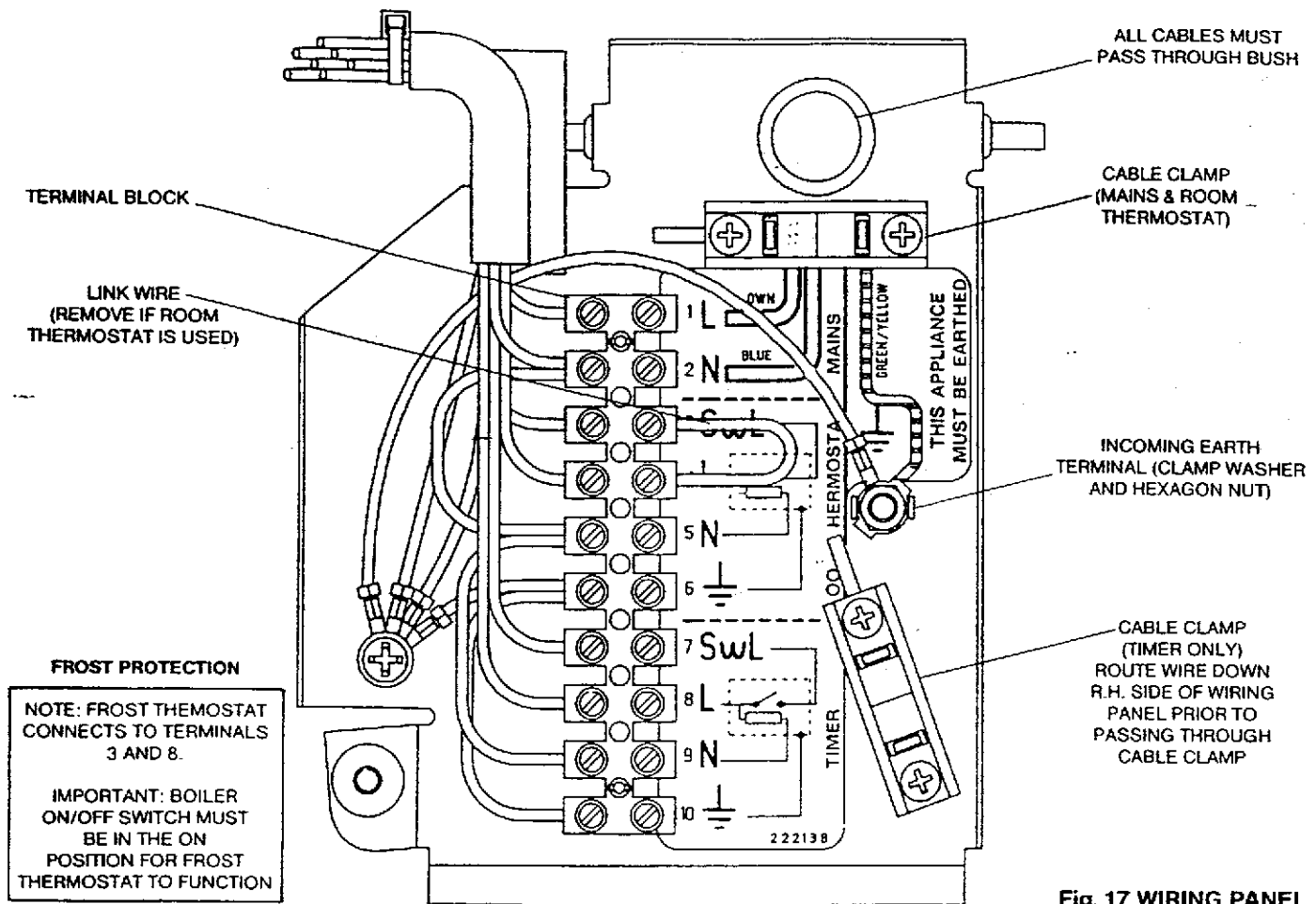

Fig. 17 WIRING PANEL

COMMISSIONING

Each Lynx 2 Combination Boiler has been through a rigorous test procedure at our factory and should not require any further adjustment. If in the unlikely event of the appliance not operating correctly please turn to the Fault Finding and Logic Sequence charts on pages 34 and 33 respectively.

1. ELECTRICAL INSTALLATION

Conduct a preliminary electrical test by checking: for short circuits, fuse failure, incorrect polarity, earth continuity and resistance to earth. If a fault has occurred on the appliance, the fault finding procedure should be followed. See page 34.

2. GAS INSTALLATION

The whole of the gas installation including the meter, should be inspected and tested for soundness and purged in accordance with the recommendations of BS 6891. Purging air from the gas line may be carried out by loosening the union on the gas service cock and purging. Retighten the union when completed and check for gas soundness.

N.B. Open all doors and windows, extinguish naked lights and DO NOT SMOKE when carrying out the gas soundness tests and purging.

3. INITIAL LIGHTING (See Fig. 18)

WARNING

Before lighting the Combination Boiler, ensure that the boiler inner cover has been correctly fitted. The outer casing should be left off for the time being. Carry out the following procedure in the order listed.

- Thoroughly flush out the whole of the heating system with cold water.
- Fill and vent the system until the pressure gauge registers 1.5 bar (21.5 psi) and examine for leaks. During filling ensure that the plastic cap on the automatic air vent is not tight and air can vent. **Do not tighten the air vent cap after filling.**
- Check the operation of the pressure relief valve by further raising the water pressure until the valve lifts. This should occur at approx 3 bar (See Fig. 18).
- Release water from the system using the pressure relief valve (access is improved by lowering the wiring panel) until the minimum system design pressure is reached. (Generally 0.5 bar).

Set the pressure gauge indicator to coincide with this pressure.

NOTE. The pre-charge pressure of the expansion vessel should not be less than the hydrostatic head.

Check the pump spindle is free to rotate by removing the vent plug and rotating the spindle using a small flat blade screwdriver. Replace plug.
- Check that the boiler on/off switch is Off and the mode switch is set to the CH OFF position. (Mid position)
- Check that the DHW and CH thermostats are set to minimum.
- Check the Gas service cock is ON.

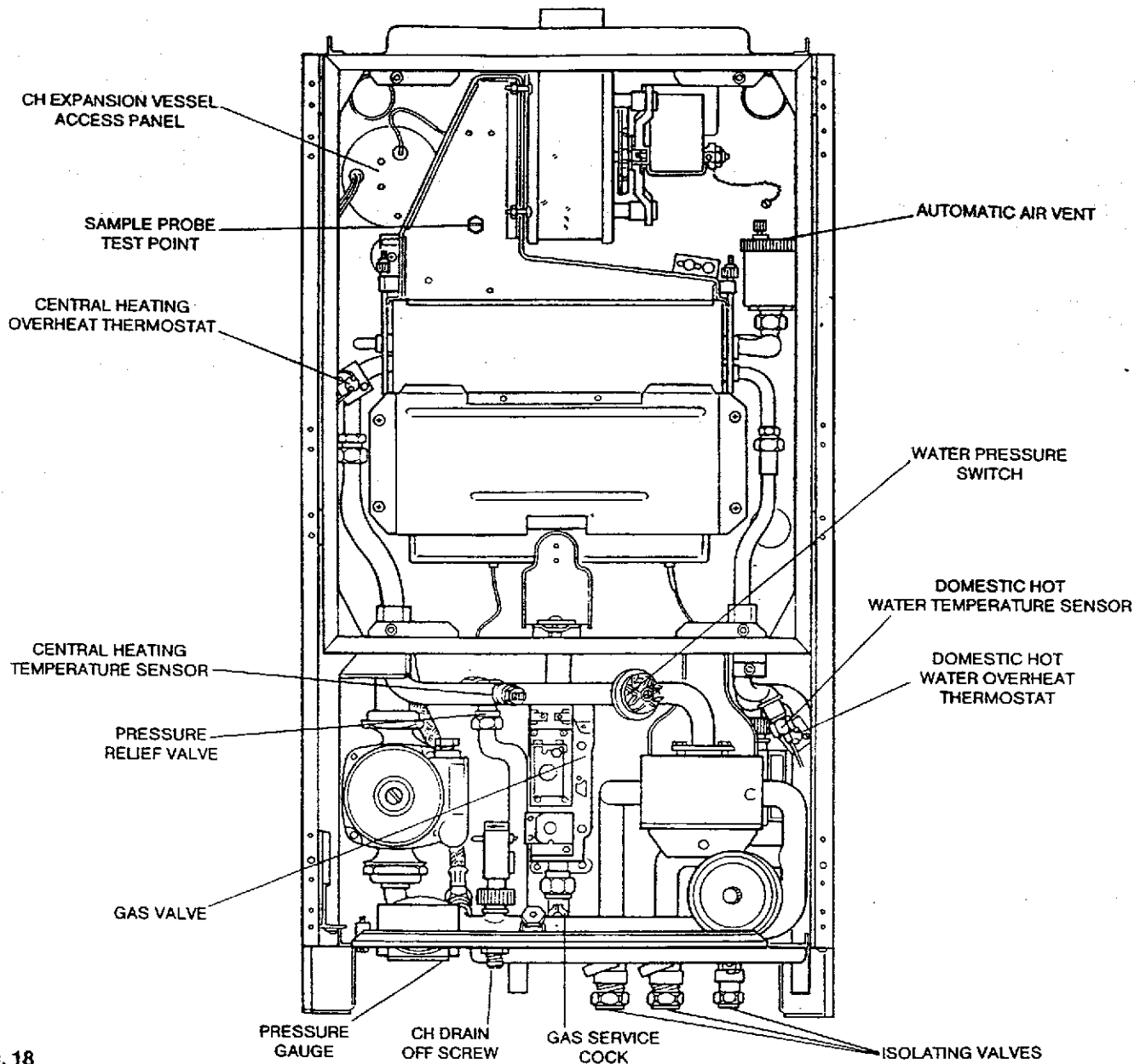

Fig. 18

- h) Check that the boiler isolating valves and radiator valves are open.
- i) Check that any time controls are in an ON condition, and any room thermostats are calling for heat.
- j) Switch ON the main electricity supply to the combination boiler at the wall isolating switch.
- k) Switch the boiler on/off switch ON.
- l) Turn the HOT WATER thermostat to 'max'.
- m) Fully open a D.H.W. tap. (After a short delay the boiler will fire, the Demand, Water Heating and Ignition L.E.D.s will glow). When the flame has established the Flame L.E.D. will be illuminated, and the Ignition L.E.D. will extinguish.
- n) Turn off the D.H.W. tap.

WARNING.

When the appliance is operating, wiring in the area around the gas valve will be live. When it is necessary in the following sections to work in this area temporarily isolate the electrical supply. However this can not be done when adjusting the gas pressure therefore extra care must be taken during this operation.

Where it is necessary to disconnect a modulator coil wire (section q.) it should be taped.

- o) Open the controls panel (one screw) and swing open to left hand side. Loosen or remove the Outlet (Burner) pressure test point screw in the gas valve body, and fit a pressure gauge to the test nipple via a flexible tube. (see Figs. 25 & 26).

WARNING. The pipes under the appliance could be hot, avoid contact with bare skin.

- p) Fully open all domestic hot water outlets, vent flexible hose connections to the washing machine and dishwasher. Operate the boiler for 10 minutes to stabilise the burner temperature and remove air from the domestic hot water distribution system. If this is not done the internal water flow switch will not function properly.

Test for gas soundness around the gas components using leak detector fluid.

- q) Check the minimum burner pressure (from Table 4) by disconnecting one of the Modulating Coil electrical connections (wire colours Red or Black). Note. The modulating coil connections are 24V only. See Figs. 25 & 26.
- r) Reconnect and check maximum burner pressure against Table 4. If any adjustment is necessary see Section 4, Gas Pressure Adjustment.

4. GAS PRESSURE ADJUSTMENT

NOTE: The gas pressures are set at the factory and should not require further adjustment, if gas pressure readings are being obtained which differ from that stated in Table 4, check using the pressure test point on the gas valve (see Figs. 25 & 26) that the inlet pressure is correct and that the appliance is at full gas rate. To ensure this always put a high water flow through the domestic hot water side of the system when measuring the maximum gas pressure.

Adjustment of the Modulating Valve

The Lynx 2 is fitted with either a S.I.T. or Honeywell Gas Valve. Determine which valve is fitted to your boiler and refer to the relevant diagram. See Figs 25 & 26 or read name off gas valve.

Set the pressures to the values in Table 4 by adjusting the gas valve in the following manner.

NOTE: It is important to note the order in which the maximum and minimum pressures are set for the appropriate gas valve fitted to the appliance.

HONEYWELL CONTROLS

The minimum pressure must always be set before adjustment of the maximum pressure.

Adjusting Minimum Pressure (see Fig.19)

- (i) Remove Cover (D)
- (ii) Disconnect one of the electrical connections of the Modulating Coil. (C).
- (iii) The minimum rate pressure adjustment has to be done with decreasing pressure, by turning the minimum rate adjustment nut (B) anti-clockwise until the desired minimum outlet pressure is obtained.
- (iv) Reconnect the electrical connection of the Modulating Coil.

Adjusting the Maximum Pressure (see Fig.19)

Adjust the maximum pressure by turning the maximum rate adjustment nut (A) clockwise to increase the pressure, until the desired pressure is obtained. (See table 4). Turn off the DHW tap.

Replace Cover (D).

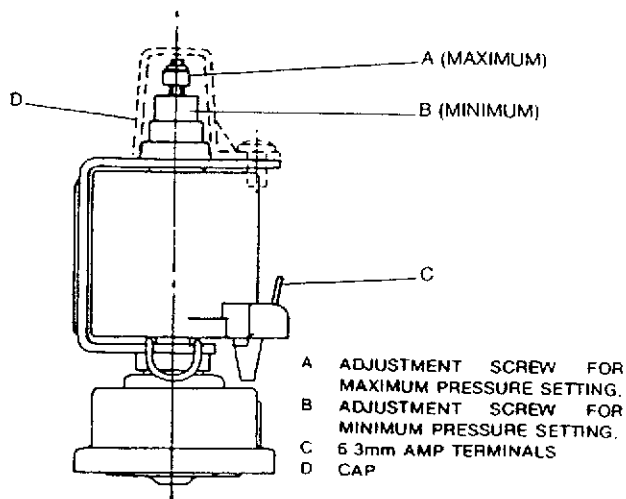

Fig. 19

	Pressure	Tolerance	Gas Rate
Maximum Pressure	13.4 mbar	13.74 mbar 13.05 mbar	2.73 cu.m/hr 96 cu.ft/hr
Minimum (Ignition) Pressure	1.0 mbar	1.05 mbar 0.95 mbar	0.98 cu.m/hr 34.6 cu.ft/hr
Inlet Pressure 20 mbar (8" w.g.)			

TABLE 4. GAS PRESSURES

SIT CONTROLS

The maximum pressure must always be set before adjustment of the minimum pressure.

Adjusting the Maximum Pressure (See Fig.20)

- (i) Remove Cover (C) by twisting it anticlockwise 90 degrees and levering off with a small screwdriver.
- (ii) With a 10mm spanner turn nut (B), (Clockwise to increase pressure). Adjust to the value for maximum pressure stated in Table 4.

Adjusting the Minimum Pressure (See Fig.20).

This adjustment is only to be made after the maximum setting has been completed.

- (i) Disconnect one of the electrical connections of the modulating coil.
- (ii) Using a 10mm spanner hold nut (B) and turn screw (A) with a screwdriver (A clockwise rotation will increase the pressure). Adjust to the value for minimum pressure stated in Table 4.
- (iii) Reconnect the electrical connection to the modulator.
- (iv) Check maximum and minimum settings. Repeat adjustment if required.
- (v) Replace cover (C).

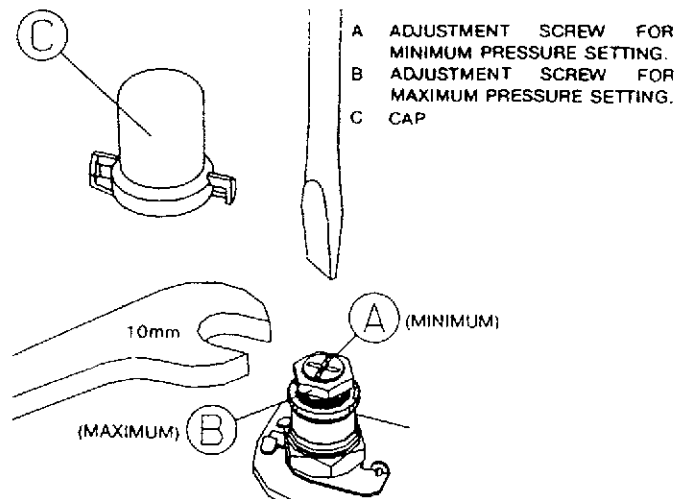

Fig. 20

After the setting operation remove the pressure gauge tube from the gas valve body and tighten or refit the pressure test point screw. Close the control panel and secure with the screw provided.

5. PRODUCTS OF COMBUSTION MEASUREMENT

If required the combustion performance can be assessed by placing a suitable sampling probe into the test point on the fluehood.

Typical values are,

CO. 0.004%

CO₂. 6.60%

6. DHW FLOW RATE No adjustment is required

The Domestic Hot Water flow rate is set automatically within the appliance. The flow control device will provide a water flow rate of approximately 7.5 litres/minutes at 0.8 bar mains pressure. As the mains pressure rises the flow rate will increase to a maximum of 10 litres/minute.

7. CENTRAL HEATING

- a) Ensure that all the external controls such as a clock or room thermostat are switched 'ON'.
- b) Set the CH MODE switch to CH Timed (if system fitted with Timer) or CH24 Hours. The appliance will operate in accordance with the pre-selected temperature demand set on the right hand temperature control thermostat.

8. THERMOSTAT CONTROLS

a) Central Heating

The right hand control knob enables you to control the temperature of the CH water as it leaves the appliance. This knob can be set between Min and Max setting. The graduation Min to Max correspond approximately to a temperature of 60 deg C to 85 deg C. Under a minimum load condition the flow temperature can rise to 90 deg C.

The appliance is fitted with a CH MODE switch which will allow you to switch off the central heating during the summer months (mid position).

b) Hot Water

The left hand control knob enables you to control the temperature of the domestic hot water as it leaves the appliance.

The knob can be set between Min and Max. The graduation Min to Max corresponds approximately to a temperature of 35 deg C to 65 deg C.

9. APPLIANCE PROTECTION DEVICES

The appliance is fitted with several protection devices. Operation of any of these devices will result in the appliance failing to operate and the RESET light will be illuminated on the front panel.

To Reset the appliance depress the RESET switch on the underside of the boiler (marked 'R'), hold in that position for 10 seconds and release. The appliance should now perform normally.

If this is not the case refer to the Fault Finding Chart on page 34 of these instructions.

NOTE:

While the appliance is being used to provide hot water at any draw off point, the central heating will not operate. When hot water is no longer required the appliance will automatically revert to central heating.

10. Refit the Outer Casing and Isolator Cover Panel.

11. HANDING OVER TO THE USER

After completion of installation and commissioning of the system, the installer should hand over to the Householder by the following actions:

- a) Hand the 'User's Guide' to the Householder and explain his/her responsibilities under the 'Gas Safety (Installation and Use) Regulations 1984'.
- b) Explain and demonstrate the lighting and shutting down procedures.
- c) Demonstrate the operation of the boiler including the use and adjustment of all system controls. This then ensures the greatest possible fuel economy consistent with household requirements of both heating and hot water consumption. Advise the User of the precautions necessary to prevent damage to the system, and to the building, in the event of the system remaining inoperative during frost conditions.
- d) Explain the function and the use of the RESET, CH MODE and Boiler ON/OFF switches.
- e) Explain and demonstrate the function of time and temperature controls, radiator valves, etc. for the economic use of the system.
- f) If a Time Control is fitted (internal or external), then draw attention to the clock 'User's Instructions' and hand them to the householder.
- g) Stress the importance of regular servicing by a qualified Heating Engineer and that a comprehensive service should be carried out AT LEAST ONCE A YEAR.
- h) Explain the function of the LOW SYSTEM PRESSURE indicator light.
- i) If a frost thermostat is fitted to the system it must be explained that the boiler ON/OFF switch must be in the 'ON' position to provide protection if the appliance is left OFF during winter periods.

Service Section

Where it is necessary to replace a gasket that relies on adhesive for securing – this adhesive will be supplied with the gasket in the spares kit.

To ensure continued efficient operation of the appliance it is necessary to carry out servicing and cleaning at regular intervals. The frequency of cleaning will depend upon the particular installation conditions and usage but in general, once per year should be adequate

Prior to servicing,
Remove the outer case (see instruction under 'Routine Maintenance'). Operate the appliance by turning On a hot water tap to a high water flow and observe the main burner.

WARNING

Before the start of any maintenance work, **disconnect** the mains **electricity** supply to the appliance by removing the plug from the socket or by switching off at the external isolating switch.

The **gas** distribution pipework and all associated appliances (including the boiler) must be checked for gas soundness.

The appliance **gas** supply should be isolated at the gas service cock, (one quarter turn of square spindle) if dismantling gas carrying components.

Look through the sight glass and check that the flame covers all the flame ports and is of a light blue colour. Yellow flames and excessive lifting of flames indicate poor combustion.

It is preferable to measure the CO% and CO₂% content of the flue gas. This is achieved by placing a suitable sampling probe into the test point on the fluehood.

Typical values are:-

CO	0.004%
CO ₂	6.6 %

The following notes apply to the appliance but it should be remembered that attention must also be paid to the heating and hot water systems in the property with special attention to radiator valves, thermostats, clocks, leaking hot water taps etc.

IMPORTANT

After completing any servicing or replacement of a gas carrying component, it is essential that a test for gas soundness is made and functional checks or controls operation carried out.

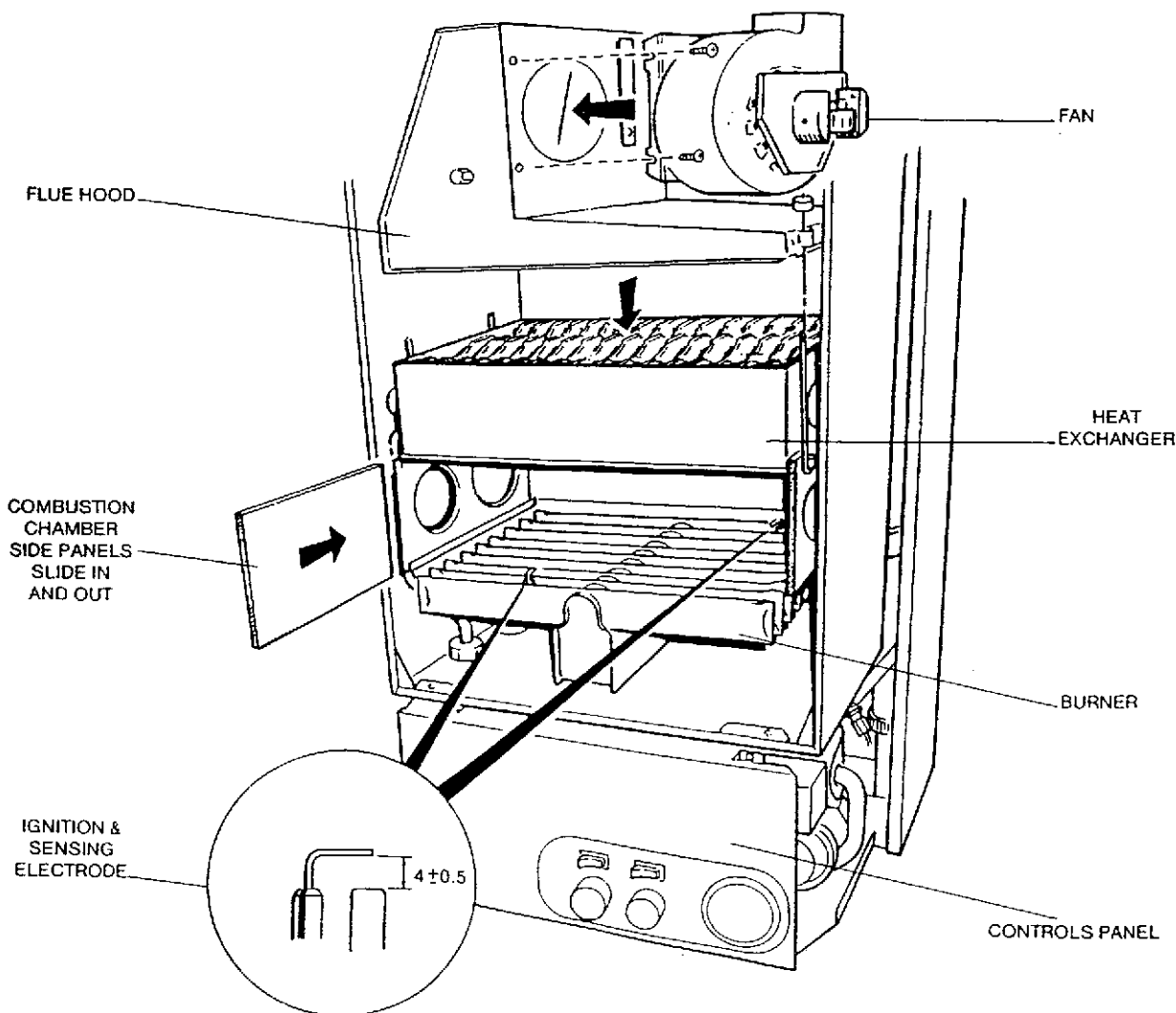

Fig. 21

ROUTINE MAINTENANCE

(Carry out the following sequence 1-10)

1. REMOVE THE OUTER CASING (See Fig. 13) Page 12- Installation Section).

- a. Remove the single securing screw located at the base of the outer casing.
- b. Ease the base of the outer casing forward approximately 50mm and lift to release the casing from the securing hooks at the top of the appliance.
- c. Guide the casing off the appliance and remove. Place in a safe position away from the immediate working area.

2. REMOVE THE INNER COVER

- a. Remove the four securing screws and remove the cover.

3. REMOVE THE FAN ASSEMBLY

- a. Disconnect the two electrical connections from the fan motor winding and the earth connection from the motor bearing housing.
- b. Support the fan and remove the two fixing screws from the front edge of the fan mounting plate. Lower the fan and carefully withdraw it from the appliance. Place in a safe place until required.

4. REMOVE THE FLUE HOOD

- a. Remove the flexible tube from the pipe emerging from the left hand side of the fluehood.
- b. Slacken the screw on the left-hand rear of the flue hood (but do not remove) and fully remove the two remaining screws.
- c. Remove the two knurled nuts and retaining rods. Lift out the flue hood to expose the top surface of the heat exchanger.

5. REMOVE THE COMBUSTION CHAMBER FRONT PANEL

- a. Remove the four screws securing the combustion chamber front panel.
- b. Remove the panel ensuring that the insulation remains in position on the panel. The underside of the heat exchanger is now exposed.

6. REMOVE THE BURNER

- a. Remove the burner fixing screw at the front of the burner, and disconnect the left hand sensing electrode lead. (Do not pull on the lead).
- b. Pull the burner forward, releasing it from the injector. Further forward movement of the burner will allow access for removal of the right hand spark lead from the electrode.

NOTE:

It is unnecessary to remove any other components for annual servicing. To measure the mains/burner pressures it will be necessary to swing sideways the control panel.

This is done by undoing the securing screw at the top right hand side of the panel, and swinging the whole control assembly to the left hand side.

If the boiler has been operating, care must be taken to avoid contact with the hot water pipes on the underside of the appliance.

7. TO INSPECT AND CLEAN THE APPLIANCE (See Fig. 21)

- a. Inspect the heat exchanger for any blockage. Deposits of any material should be brushed away using a soft brush. **Note: Do not use brushes with metallic bristles.**
- b. Examine internal pipe work connections and automatic air vent for any water leaks. Rectify if necessary.
- c. Examine the combustion chamber insulating material and renew if damaged. To remove, slide the side insulation panels forwards to disengage from the combustion chamber and pull the rear insulation out from its top edge.
- d. Remove and examine the main burner injector, clean or renew as necessary.
- e. Inspect the main burner and remove any deposits with a soft brush. Check the electrodes for damage or deterioration. Ensure that the spark gaps are correct to dimensions specified in Fig. 21. Clean or renew as necessary. Do not bend the electrodes as the insulating material may crack.
- f. Examine the fan for any mechanical damage (including gaskets), check to ensure free running of the fan wheel. Clean the wheel if necessary with a soft brush.

NOTE: It is essential that a good seal is made at the outlet to the fan, renew the sealing ring or main gasket if there are any signs of damage or deterioration, using the adhesive supplied in the gasket kit. See sections 15 & 16 of **Component Replacement**.

- g. Examine flue duct and flue hood and ensure that there is no obstruction.

Reassemble all components in reverse order. During re-assembly check the Case Seal for damage or deterioration and renew if necessary.

8. GAS PRESSURES - ADJUSTMENT

See **Commissioning Section**. Page 15.

9. THE SEALED SYSTEM

Check that the pressure in the system is being maintained. The pressure gauge is fitted with a moveable red marker which indicates the initial filling pressure of the system when cold. If the pressure gauge needle indicates a lower pressure than the red marker or the 'Low System Pressure' light on the appliance front panel is illuminated, this shows the system has lost pressure and should be re-pressurised. The correct procedures are shown in the installations section. See 'permissible methods of filling' Page 8.

10. OTHER COMPONENTS

No further servicing is required on any other appliance components. It is advisable to operate the three isolating taps to maintain free operation. It is recommended that the pressure relief valve is operated during servicing. It may occasionally be necessary to replenish the pre-charge in the expansion vessels. This can be readily achieved by use of an air pump or compressed air line. Access can be made to the charging points on the respective vessels, as follows:

a. **Central Heating expansion vessel** – access is made by removing the air pressure switch mounting plate. To do this remove the fan and fluehood (See

section 3 and 4). Note the position of the switch assembly and undo the three outer securing screws. Remove the mounting plate and air pressure switch assembly. Access to the vessel charge point can now be made. When replacing the air pressure switch assembly ensure that it is fitted in the correct position (ie. with the rubber tube at 12 o'clock)

b. **Domestic Hot Water expansion vessel** – access is made by opening the controls panel. The vessel charge point can now be connected. Re-pressurise the vessel to 3.5 bar (51 p.s.i.).

Note. If a portable pump will not achieve this pressure remove from the appliance and recharging on a compressed air line. (see section 24, Expansion vessel D.H.W.).

COMPONENT REPLACEMENT

WARNING

Before attempting to remove any component from this appliance first disconnect the mains electricity supply by removing the plug from the wall socket or by switching off the appliance at the external isolating switch. **Note:** The appliance ON/OFF switch **must not** be used as the means of isolating, as this switch does leave parts of the appliance electrically LIVE.

Notes:

The appliance gas supply should be isolated at the boiler gas service cock (one quarter turn of square spindle).

The Central Heating and Domestic Hot Water circuits can similarly be isolated at their respective valves. A drain point is provided in the appliance heating circuit under the appliance (see Fig.15).

NOTE: Before removing any component from the central heating circuit on the appliance, reduce the pressure by closing the isolating valves and opening the pressure relief valve. Access to the valve is improved by lowering the wiring panel.

IMPORTANT

After removal or replacement of any gas carrying components a test for gas soundness must be made.

1. CENTRAL HEATING OVERHEAT THERMOSTAT (See Fig. 18)

- Remove the outer casing and the inner cover as previously described. See sequences 1 and 2 'Routine Maintenance'.
- The thermostat is located on to the heating flow pipe situated on the left hand side of the heat exchanger. Disconnect the two electrical leads.
- Undo the two fixing nuts and remove the thermostat from the mounting plate.
- Fit the new overheat thermostat taking care not to touch the exposed disc of the thermostat. Reassemble in reverse order. Polarity of the electrical connections is not important.

2. DOMESTIC HOT WATER OVERHEAT THERMOSTAT (See Fig. 18)

- Remove the outer casing as described previously. See sequence 1, 'Routine Maintenance', and open the control panel (1 screw).
- Remove the thermostats two securing pillars and pull the thermostat clear of the mounting screws.
- Disconnect the electrical leads from the thermostat.
- Fit the new thermostat and reassemble in reverse order.

3. SENSOR AND IGNITION ELECTRODE (See Fig. 21)

- Remove outer casing, inner cover, combustion chamber front, and burner assembly as previously described. See sequences 1, 2, 5 and 6 'Routine Maintenance'.
- Remove the appropriate electrode retaining screw and lift the electrode out of its support bracket.
- Fit new electrode(s) and reassemble in reverse order, checking that the gap measures 4mm +/- 0.5mm.

4. SENSOR AND IGNITION LEAD

Sensor Lead (see Fig. 23)

- Remove the outer casing and inner cover as described. See sequences 1 & 2 'Routine Maintenance'. Open the control panel by undoing the securing screw and swing clear.
- Remove the sensor lead from the electrode.
- Unscrew the 1 way terminal connector. Separate the leads and pull the sensor lead through the casing grommet.
- Fit new lead in correct position.
- Reassemble in reverse order.
(The 1 way terminal block is re-useable).

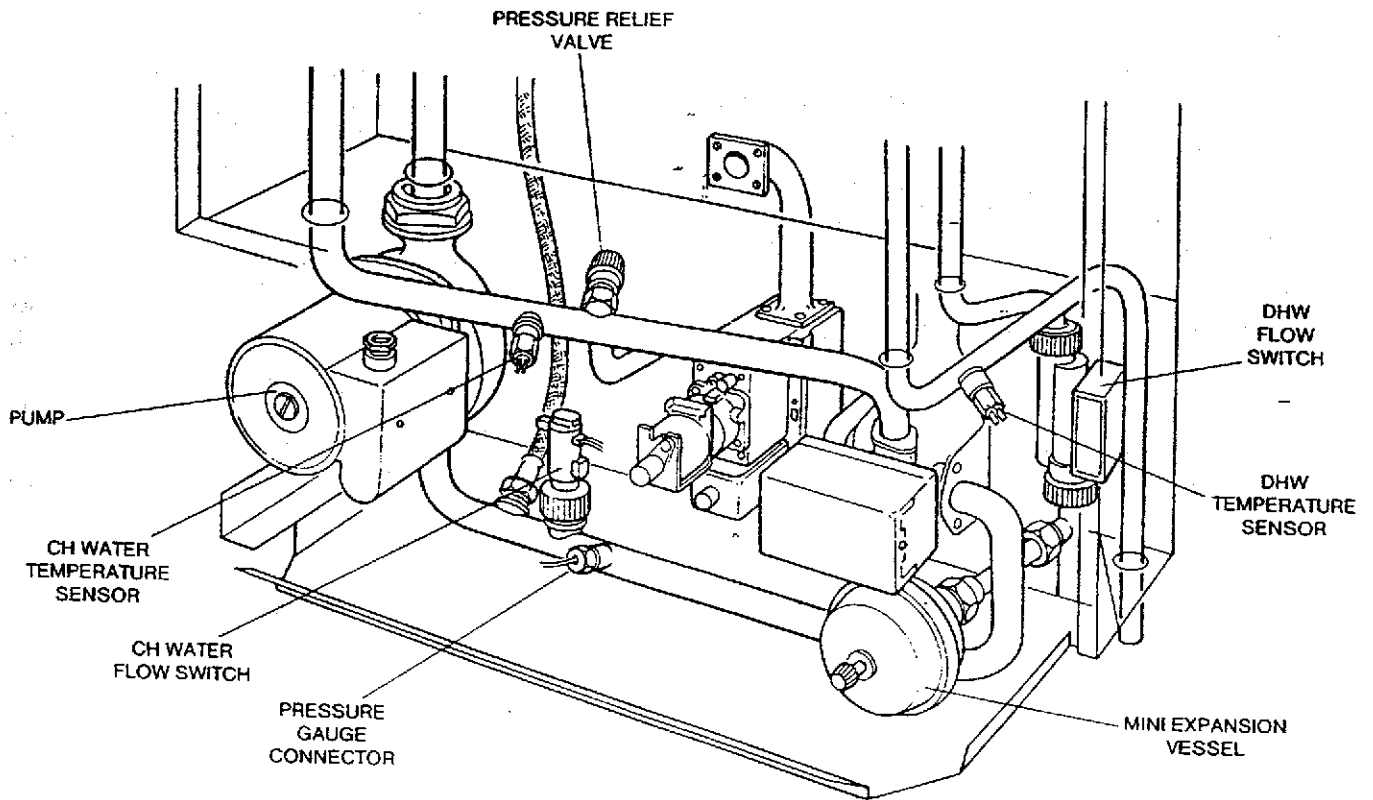

Fig. 22

Ignition Lead

- a. Carry out as a. above.
- b. Remove combustion chamber front and burner as previously described. See sequence 5 & 6 'Routine Maintenance'
- c. Disconnect the lead from the electronic control board and ignition electrode. Remove, making a note of the route.
- d. Fit new lead in correct position.
- e. Re-assemble in reverse order.

5. BURNER (See Fig. 21)

- a. Remove the outer casing, inner cover, combustion chamber front and burner assembly as previously described. See sequences 1, 2, 5 and 6 'Routine Maintenance'.
- b. Remove the electrodes from the burner and re-assemble onto the new burner. (Check electrode gap is 4mm +/-0.5).
- c. Fit the new burner and ensure the burner is pushed back on the injector. Reassemble in reverse order.

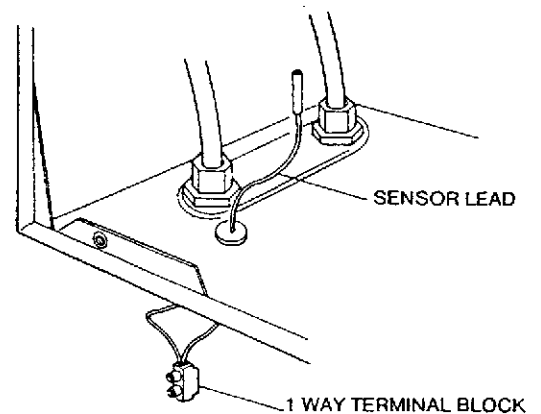

Fig. 23

6. INJECTOR

- a. Remove the outer casing, inner cover, combustion chamber front and burner assembly as previously described. See sequences 1, 2, 5 and 6 'Routine Maintenance'.
- b. Unscrew the burner injector from its housing at the rear of the combustion chamber.
- c. Fit the new injector with Aluminium sealing washer and tighten.
- d. Reassemble in reverse order.

7. GAS CONTROL VALVE (See Fig. 24)

The Lynx 2 is fitted with either a 'SIT' Gas Control Valve or a 'HONEYWELL' Control Valve. Establish which make is fitted for future reference. The removal procedure is the same for both types.

- Remove the outer casing, inner cover, combustion chamber front and burner assembly as previously described. See sequence 1, 2, 5 and 6 'Routine Maintenance'. Open the control panel by undoing the securing screw and swing open.
- Remove the 2 off electrical connectors from the modulating valve and 2 off connectors on the first solenoid valve.
- Loosen the Union nut on the gas service cock positioned on the underside of the appliance.
- Loosen the gas control valve lower fixing screw (hexagon headed).
- Support the valve and remove the four fixing screws which hold the burner feed pipe to the boiler inner casing back panel.
- Lift the gas valve assembly clear of the gas service cock. Pull the gas control forwards so that the assembly passes between the horizontal flow pipe, 3-way valve and C.H. flow switch (See Fig. 24).
- Before the new gas control valve is fitted transfer the nut, liner, burner feed pipe and valve mounting screw. Replace the 'O' ring seal.
- Reassemble in reverse order ensuring that the black and red wires (low voltage) are connected to the modulator valve (see Figs. 25 & 26). Polarity is not important. The brown and grey wires (240 volts) MUST be connected to their corresponding connectors on the first solenoid valve.

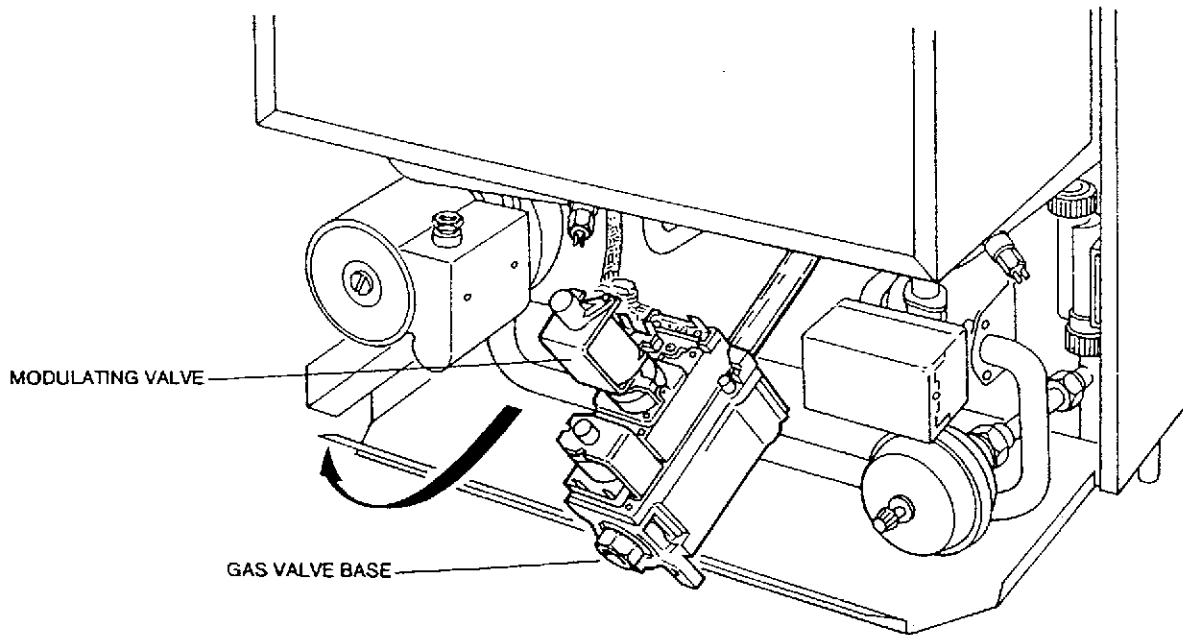

Fig. 24 GAS VALVE REMOVAL

HONEYWELL VALVE ILLUSTRATED

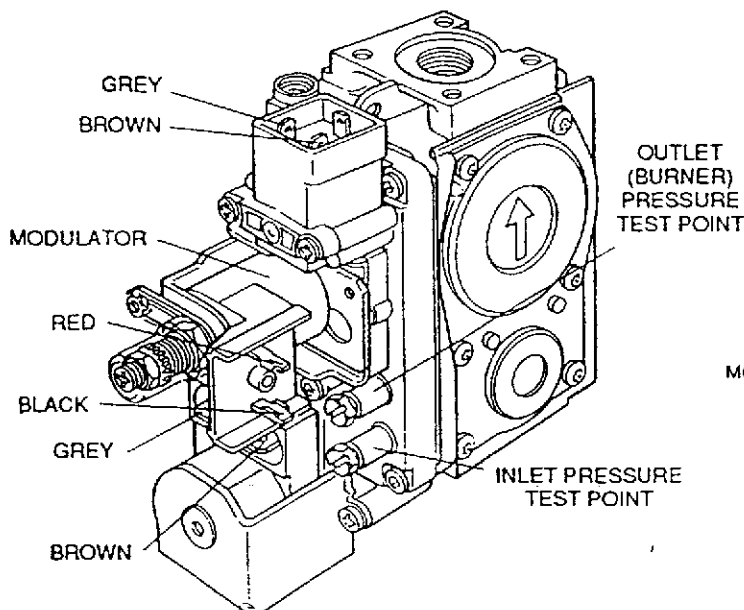

Fig. 25

SIT

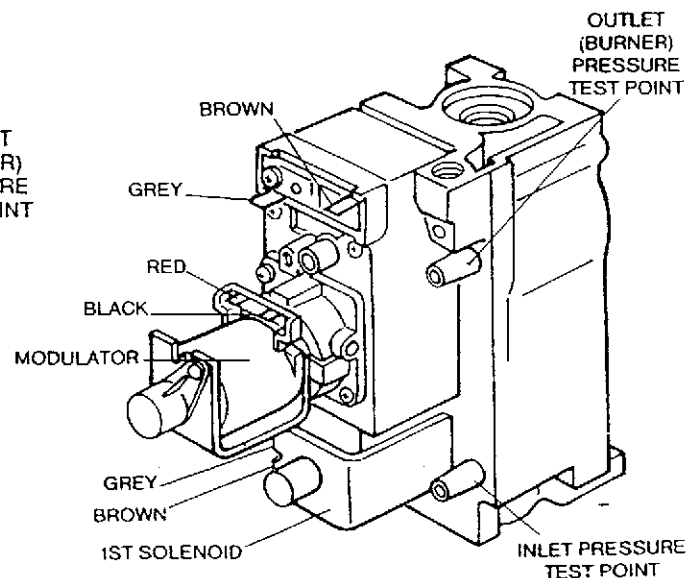

Fig. 26

HONEYWELL

8. MODULATING VALVE

Establish which make of valve is fitted and proceed to the relevant section.

SIT CONTROLS

MODULATING COIL (See Fig. 25)

- a. Remove the outer casing as described previously. See sequence 1 'Routine Maintenance'.
- b. Open the control panel. (1 screw).
- c. Disconnect the electrical connections to the modulating valve. (Red and Black).
- d. Remove the clear plastic cover by twisting it anti-clockwise 90 degrees and levering off with a small screwdriver.
- e. Using a 14mm spanner unscrew the complete inner cartridge and remove with niting plate.
- f. Lift off the solenoid coil and remove from metal bracket, (retain the spring washer).
- g. Replace in reverse order ensuring the notch in the niting plate is located over the raised pip and the spring washer is positioned to the top of the new solenoid coil.
- h. Connect the red and black wires to the connectors on the valve. Polarity is not important.
- i. Reset the gas pressure – see Commissioning Section, Page 17.

9. FIRST SOLENOID VALVE COIL (See Fig. 25)

- a. Remove the Gas valve as stated in Section 7.
- b. Disconnect the electrical connections to the first solenoid valve.
- c. Remove the solenoid valve (2 screws).
- d. Replace the solenoid valve in reverse order ensuring that the brown and grey wires (240 volts) are only connected to the first and second solenoid valves.
- e. Refit the Gas valve to the appliance.
- f. Re-commission the appliance as described in the Installation Instructions, Page 17.

10. SECOND SOLENOID VALVE (See Fig. 25)

- a. Remove the gas valve as stated in Section 7.
- b. Disconnect the electrical connections to the second solenoid valve.
- c. Remove the second solenoid valve (2 screws).
- d. Replace the solenoid valve in reverse order ensuring that the brown and grey wires (240 volts) are only connected to the first and second solenoid valves.

- e. Refit the Gas valve to the appliance.

- f. Re-commission the appliance as described in the Installation Instructions, Page 17.

HONEYWELL CONTROLS

8A. MODULATING COIL (See Fig. 26)

- a. Remove the outer casing as described previously. See sequence 1 'Routine Maintenance'.
- b. Open the control panel. (1 screw).
- c. Disconnect the electrical connections to the modulating valve. (Red and Black).
- d. Note the position of the coil and remove the modulating valve assembly by undoing the two securing screws.
- e. Fit the replacement valve assembly in the same position using the pre formed rubber seal supplied with the coil.
- f. Connect the red and black wires to the connections on the valve. Polarity is not important.
- g. Reset the gas pressure – see commissioning instructions.
- h. Replace remaining components in reverse order.

9A. FIRST SOLENOID VALVE COIL

- a. Remove the gas valve as stated in Section 7.
- b. Slide out the spring loaded retaining clip from behind the first solenoid coil (use long nosed pliers) and withdraw the coil.
- c. Replace and refit all components as Section 7.

10A. SECOND SOLENOID VALVE (See Fig. 26)

- a. Remove the outer casing as described previously. See sequence 1 'Routine Maintenance'.
- b. Open the control panel. (1 screw).
- c. Disconnect the electrical connections to the second solenoid valve, and modulating valve.
- d. Remove modulating valve and seal as Section 8.
- e. Remove the second solenoid valve (four screws). Refit using new gasket. Fit the modulating valve to the new solenoid valve.
- f. Replace in reverse order ensuring that the red and black wires (low voltage) are connected to the modulating valve. The brown and grey wires (240 volts) must only be connected to the second solenoid valve.
- g. Re-commission the appliance as described in the Installation Instructions, Page 17.

11. CASE SEAL

- a. Remove the outer casing and inner cover as previously described. See sequence 1 and 2 'Routine Maintenance'.
- b. The seal is secured at four corner points. Lift corner pieces out of retaining holes.
- c. Fit new seal and re-assemble, in reverse order.

12. C.H. MODE AND ON/OFF SWITCHES (see Fig. 27)

- a. Remove the outer casing as previously described, see sequence 1 'Routine Maintenance'.
- b. Open the control panel by undoing the single securing screw and swing open. Loosen the two hexagon nuts retaining the controls cover and pull the top of the cover forwards. Disconnect the two lower retaining lugs.
- c. Make a note of the wire positions onto the switch/s and disconnect wires.
- d. Using a small screw driver press the retaining lugs on the switch body sides inwards and remove the switch from the face of the control panel.
- e. Fit new switch and reassemble in reverse order. Ensure that the switch is the correct way round in the panel, i.e. when the ON/OFF switch is ON, the indicator line can be seen on the left hand side, when viewed from the front panel. The C.H. Mode switch is not handed.
- f. Re-fit wires in correct positions (see Fig. 27)

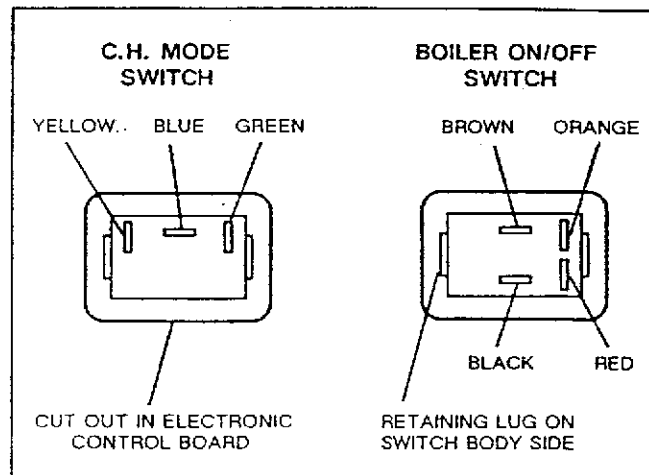

Fig. 27 VIEW FROM REAR OF CONTROL PANEL

13. ELECTRONIC CONTROL (See Fig. 28)

- a. Remove the outer casing as previously described. See sequence 1 'Routine Maintenance'.
- b. Swing open the control panel by undoing the securing screw, and remove the cover (two nuts). The electronic controls are now exposed.
- c. Remove the Spark Electrode Lead connection from the right hand side of the printed circuit board.
- d. Pull off the two thermostat knobs from the front of the control panel.
- e. Remove the connections from the two rocker switches, and all Molex connectors making note of all positions.
- f. Remove earth lead screw from top left hand side of control panel.
- g. Remove the six securing screws. The board can now be exchanged, or stored in a clean safe place until required.
- h. Reassemble in reverse order; when replacing the Molex plugs ensure that the connections are correctly aligned.

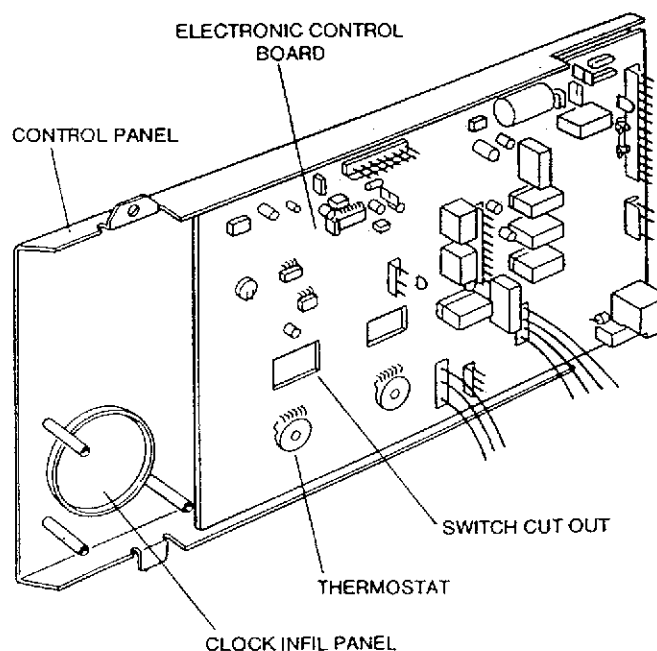

Fig. 28

14. AIR PRESSURE SWITCH

- a. Remove the outer casing, inner cover, fan and fluehood as previously described, see sequences 1, 2, 3 and 4 'Routine Maintenance'.
- b. Undo the three screws securing the air pressure switch mounting plate. Make note of the position and remove the assembly.
- c. Disconnect the flexible tube from the lower nipple (marked L) and electrical connections from the air pressure switch. Note position of switch on panel and remove two switch mounting screws.
- d. Fit new pressure switch and reassemble in reverse order ensuring that the switch terminals are positioned correctly.
- e. Check the pressure tube, replace if damaged.
- f. Reassemble in reverse order.

15. FAN

- a. Remove the fan from the unit as described previously. See sequences 1, 2 and 3 'Routine Maintenance'.
- b. Fit new fan into position ensure the fan is located correctly (see Fig. 29) and that a good seal is made between the fan outlet and the top of the inner case.
- c. Reassemble in reverse order and check that the electrical wiring and connections are not damaged.

16. FAN OUTLET SEAL

- a. Remove the fan from the unit as described previously. See sequences 1, 2 and 3 'Routine Maintenance'.
- b. Remove the old fan outlet seal and any residue adhesive
- c. Using the Silicone Adhesive/Sealant supplied with the seal, fix the new seal in position using the lip on the fan outlet casting as a guide.
- d. Reassemble in reverse order.
- e. Run the appliance for approximately 3 minutes to cure the adhesive.

17. TEMPERATURE SENSOR. D.H.W & C.H. (see Fig. 22)

- a. Remove the outer casing as described previously. See sequence 1 'Routine Maintenance'.
- b. Open the control panel by undoing the securing screw.
- c. Before removing the hot water or central heating sensor, first close the isolating valves for the circuit involved.
For CH reduce the system pressure by opening the pressure relief valve (access is improved by lowering the wiring panel) then drain the water from the heating circuit by removing the drain plug.

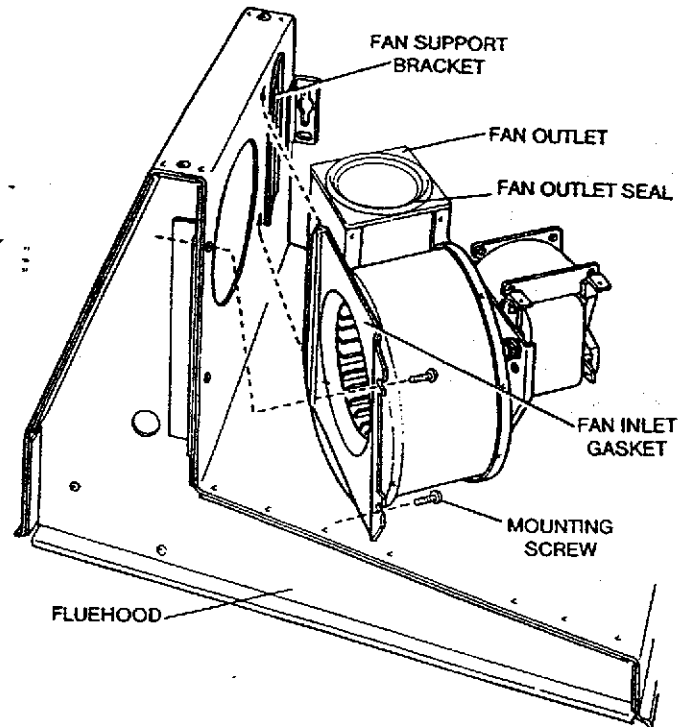

Fig. 29 FAN ASSEMBLY

For DHW close the 15mm cold water isolating valve, open the lowest tap then remove the D.H.W. drain screw on the isolation valve (see Fig. 14).

- d. Disconnect the electrical connection from the sensor(s) and unscrew from its housing.
- e. Refit the new sensor(s) and washer. Reassemble in reverse order. If necessary (C.H sensor only) recharge the C.H. system as described in the Installation Instructions, and check for leaks.

18. PRESSURE GAUGE (see Fig. 18)

- a. Remove the outer casing as described previously. See sequence 1 'Routine Maintenance'.
- b. Open the control panel by undoing the securing screw.
- c. Close the central heating isolating valves, reduce the system pressure by opening the pressure relief valve, (access via wiring panel) then drain the water from the heating unit by removing the drain off screw (see Fig. 18).
- d. Remove the pressure sensing element from its housing on the pipework.
- e. Remove the pressure gauge from the the bottom tray by squeezing the two plastic gills towards the centre of the gauge. Withdraw the capillary through the cut out in the plate.
- f. Fit the new pressure gauge, in its correct position. Reassemble in reverse order. Use the new washer to seal the sensor element. Recharge the system as described in the installation instructions and check for leaks.

19. WATER FLOW SWITCH (CENTRAL HEATING) (see Fig. 22)

- a. Remove the outer casing as described previously. See sequence 1 .
- b. Close the central heating isolating valves, reduce the system pressure by opening the pressure relief valve, (access via wiring panel) then drain the water from the heating unit by removing the drain plug (see Fig. 18).
- c. Open the control panel by undoing the securing screw, and swing sideways.
- d. Remove cover from rear of control panel (loosen two hexagon nuts).
- e. Disconnect the 2 pin plug from the electronic control board. Un-clip the lead from the plastic cable tie. Undo the plastic union nut and remove the flow switch and sealing washer from the appliance.
- f. Fit new flow switch ensuring that the cable entry is towards the gas valve and is in line with the pipe. The arrow on the switch body will point to the left see Fig. 18. Reassemble in reverse order, re-charge the system as described in the installation instructions, and check for leaks.

20. WATER FLOW SWITCH (D.H.W.)

- a. Remove the outer casing as described previously. See sequence 1 'Routine Maintenance'.
- b. Open the control panel (one screw) and remove control cover (two nuts). Remove isolator cover panel from underside of appliance.
- c. Close the isolating valve on the cold water supply, drain the water out of the lowest hot tap and remove drain plug on the 15mm isolating valve, collect the residual water and dispose.
- d. Remove the mini expansion vessel by undoing the Union nut at the Cold Water inlet pipe and sliding off the plastic location tie.
- e. Undo the Domestic Hot Water Inlet connection on the underside of the combustion chamber and at the outlet of the 15mm isolating valve.
- f. Pull the pipe out of the connection under the combustion chamber and lift the pipe/flow switch assembly clear of the isolating valve upper connection.
- g. The switch supply cable can now be released from the harness clip and unplugged from the control board. Remove the switch/pipe assembly from below the appliance.
- h. Fit new flow switch to the pipework using the existing acorn fittings reassemble in reverse order, replacing seals if required. Note the switch body must be to the right-hand side when in position with the wire entering from below.

- i. Reassemble in reverse order. Open the isolating valves and re-charge the system as described in the installation instructions and check for leaks.

21. PUMP (See Fig. 22)

- a. Remove the outer casing as described previously. See sequence 1 'Routine Maintenance'.
- b. Open the control panel secured by one screw and swing sideways.
- c. Remove the terminal cover on the side of the pump housing, note the colours of the wiring and disconnect the 3 wires from the terminal block.
- d. Close the central heating isolating valves, reduce the system pressure by opening the pressure relief valve, (access via wiring panel) then drain the water from the heating unit by removing the drain off screw (see Fig. 18).
- e. Undo the two brass hexagon nuts either side of the pump.
- f. Fit the new pump and reassemble in reverse order, ensure that the pump terminal block is to the right hand side and the flow of water through the pump is upwards. The white wire must go to the live terminal (L) and the black wire to neutral (N). Re-charge the system as described in the installation instructions and check for leaks. Where applicable ensure that the pump is set to the highest speed.

22. DIVERTER VALVE

The Lynx 2 is fitted with either a 'SUNVIC' Diverter Valve or a 'HONEYWELL' Valve. Establish which make is fitted for future reference. The removal procedure is the same for both types.

NOTE

Generally it will not be necessary to replace the valve body. It is possible to replace the moving parts of the valve and the water seals without removing the valve body from the pipework. If it becomes necessary to remove the entire valve assembly see section 23.

Motor Replacement SUNVIC Potterton Part No. 910017

- a. Remove the outer casing as described previously. See sequence 1 'Routine Maintenance'.
- b. Swing open the control panel secured by one screw. The diverter valve assembly can now be accessed.
- c. Remove the two motor housing fixing screws and pull the motor assembly clear of the spindle.
- d. Unplug the 3 pin plug from the electronic control board and free the wire from the cable tie.
- e. Fit the new motor assembly ensuring the spindle is aligned with the motor drive. Ensure the wire enters via the left hand side. Reassemble in reverse order.

Motor Replacement HONEYWELL

Potterton Part No. 910016

- a. Remove the outer casing as described previously. See sequence 'Routine Maintenance'.
- b. Swing open the control panel secured by one screw. The diverter valve assembly can now be accessed.
- c. Loosen the hexagon head cover fixing screw and remove the cover from its snap fitting.
- d. Unplug the 3 pin plug from the P.C.B. and free the wire from the cable tie.
- e. Undo the two brass fixing screws and pull the motor assembly clear of the spindle.
- f. Fit the new motor assembly and reassemble in reverse order. Ensure the wire enters via the left hand side.

Note. It may be necessary to partially engage the spindle then operate the manual control lever to align the spindle drive prior to fitting securing screws

Flow Diverter Replacement SUNVIC

Potterton Part No .910019

- a. Repeat operations for Motor Replacement. a to c.
- b. Close the central heating isolating valves, reduce the system pressure by opening the pressure relief valve, (access via wiring panel) then drain the water from the heating unit by removing the drain off screw (see Fig. 18).
- c. Remove the four Pozidriv screws from the front plate and pull the plate clear of the valve body. (The front plate and seals are integral with the Flow Diverter).
- d. Ensure that the internal surfaces of the valve are clean and free from scale and install the new flow diverter assembly (on the Sunvic Valve the front plate incorporates the spindle and close off paddles). Reassemble in reverse order.
- e. Recharge the system as described in the Installation Instructions and check for leaks.

Flow Diverter Replacement HONEYWELL

Potterton Part No.910018.

- a. Repeat operations for Motor Replacement. a to c.
- b. Close the central heating isolating valves, reduce the system pressure by opening the pressure relief valve, (access via wiring panel) then drain the water from the heating unit by removing the drain off screw (see Fig. 18).
- c. Proceed using the ball and seal replacement kit Potterton Part No.910018.
(Honeywell Trade Line 272742 A CARD)

These items are to be replaced in accordance with the instructions supplied in the kit pack. Ensure that the internal surfaces of the valve are clean and free from scale before attempting re-assembly.

- d. Reassemble in reverse order.
- e. Recharge the system as described in the Installation Instructions and check for leaks.

23. DIVERTER VALVE (Complete Replacement) Potterton Part No 430032.

- a. Follow section 22a - c.
- b. Remove the motor housing as above.
- c. Close the central heating isolating valves, reduce the system pressure by opening the pressure relief valve, (access via wiring panel) then drain the water from the heating unit by removing the drain off screw (see Fig.18).
- d. Remove the six hexagon screws holding the 3 pipes to the 3 way valve body.
- e. Remove the single screw securing the diverter valve support bracket to the support strut and loosen the rear support strut fixing screw. Allow the strut to drop below the valve support bracket
- f. Remove the boiler inner casing cover (4 screws) and remove the two screws retaining the valve mounting bracket. Push the bracket from the valve and remove from the appliance.
- g. Undo the upper connectors to the central heating flow isolating valve.
- h. Twist the CH flow pipe clear from the valve body.
- i. Spring upwards the water flow pipe (valve top port) and withdraw the 3 way valve body from the bypass pipe connection by moving it to the left.
- j. Replace valve and seals
- k. Reassemble in reverse order. Recharge the system as described in the Installation Instructions and check for leaks.

24. EXPANSION VESSEL. D.H.W.

- a. Remove the outer casing as described previously. See sequence 1 'Routine Maintenance'.
- b. Remove the isolator cover panel by loosening the two hexagon headed screws on the underside of the appliance.
- c. Swing open the control panel secured by one screw. Close the isolating valve on the cold water supply. Drain the water out of the lowest hot water tap, and remove the drain screw on the isolating valve. Collect the residual water and dispose. Replace drain screw in isolator valve.
- d. Release the vessel from its securing strap and disconnect the union nut joint between the expansion vessel pipe and the vertical cold water inlet pipe.
- e. Withdraw vessel and pipe assembly, disconnect pipe from vessel and refit new component.
- f. Reassemble in reverse order, using the sealing washers and securing strap supplied. Open the isolating valve, and check for leaks.

25. EXPANSION VESSEL. C. H.

In the unlikely event of a failure of the C.H. expansion vessel it is recommended that a new vessel be fitted exterior to the boiler. It should be positioned on the C.H. Return pipe (see Fig. 4), as close to the boiler as possible

If however, the vessel must be replaced then the following procedures may be used:

Installations with vertical flue systems must be fitted with exterior expansion vessels if the flue system can not easily be raised a minimum of 50 mm.

PROCEDURE 1. Horizontal flues only.

If the clearance above the boiler is greater than 300mm proceed as follows

- a) Remove the outer casing, inner casing, fan and fluehood. See sequences 1,2,3 and 4 'Routine Maintenance'. Remove the air pressure switch mounting plate assembly. See sequence 14.b.
- b) Remove the isolator cover panel by loosening the two hexagon headed screws on the underside of the appliance and lower the wiring panel by removing the screw to the lower left of the panel.
- c) Close the central heating flow and return isolating valves and drain off the water from the boiler by opening the pressure relief valve (to reduce the pressure) and removing the drain plug.
- d) Swing open the control panel (1 screw) and undo the flexible hose connection to the horizontal bypass pipe.
- e) For rear mounted flues remove the flue elbow (3 screws) and withdraw the flue assembly from the wall. Side outlets may require removal of the flue for short lengths.
- f) Remove the expansion vessel securing bracket assembly (two nuts) and slide the vessel upwards out of the rear frame.
- g) Remove the flexible pipe from the old vessel and refit to the new expansion vessel (at this stage the pre-charge pressure can be easily checked and corrected if necessary. The pressure should be equal to the system pressure at the appliance)
- h) Fit the new expansion vessel and reassemble in reverse order using a new sealing washer. Ensure that the vessel is located correctly in the lower support bracket. Re-charge the system as described in the Installation Instructions, and check for leaks.

PROCEDURE 2

If the clearance above the appliance is less than 300mm the appliance must be removed from the wall.

- a. Remove the outer casing as described previously. See sequence 1 'Routine Maintenance'.
- b. Remove the isolator cover panel and open the wiring panel underneath the appliance (1 screw).
- c. Close all the isolating valves, reduce the pressure in the appliance by opening the pressure relief valve and drain the water in the boiler and hot water pipework.

- d. Swing open the control panel and remove the wiring panel harness connector plug PL8 from the top right hand corner of the printed circuit board.
- e. Thread the harness out of the appliance and remove the wiring panel by holding at 45 deg to the wall and twisting clockwise to disengage from the hinge bracket.
- f. Check the gas supply is isolated at the gas service cock, (turn square on spindle) and undo the union nut.
- g. Where a horizontal flue system enters the wall remove the glass fibre rope seal and disconnect the flue elbow from the top of the appliance, (3 screws), leave the flue in situ. If a vertical flue system is fitted it will require raising approximately 50mm. (2")
- h. Undo the upper most valve connections on the C.H. flow and return pipes, and the cold water supply, similarly disconnect D.H.W. flow pipe, and pressure relief pipes.
- i. Remove the bottom boiler securing screw then loosen the appliance upper securing screws and lift the boiler off the wall. Place unit face downwards on the floor.
- j. Access can now be made to the expansion vessel. Undo the flexible pipe connection to the vessel and loosen the nuts in the upper clamping bracket to release the vessel from the appliance.
- k. Fit a new expansion vessel and reassemble in reverse order, using a new sealing washer. Re-charge the system as described in the Installation Instructions, and check for leaks.

26. HEAT EXCHANGER (See Fig. 21).

- a. Follow sequences 1-6 'Routine Maintenance'. Remove the combustion chamber insulation by sliding the side panels forward and tilting the rear insulation forwards from the top. This will expose the two combustion chamber securing screws which should be removed.
- b. To remove the heat exchanger close the C.H. flow and return isolating valves and the Cold Water supply isolating valve. Reduce the pressure of the system by opening the pressure relief valve (access via wiring panel). Drain the water from the heat exchanger by removing the drain plug. Open the lowest hot water tap in the circuit then remove the drain screw on the cold water inlet isolating valve (see Fig. 14).
- c. Disconnect the electrical connections from the C.H. overheat thermostat. Swing open the controls panel and cover with a waterproof material to protect the electronics.
- d. Undo the four Union nuts at the base of the combustion chamber and lift out the heat exchanger assembly.
- e. The heat exchanger waterways can now be descaled or a replacement heat exchanger can be fitted, in which case the overheat thermostat, air vent and pipework must be transferred to the new heat exchanger. Fit new 'O' rings where necessary

- f. When fitting a new heat exchanger, before finally tightening the four Union nuts, measure the distance between the underside of the heat exchanger and the bottom of the inner casing. This distance must measure 242mm +/-1 mm. It is recommended that four lengths of copper tube 242mm long be used to space off the heat exchanger during assembly.
- g. Tighten the four Union nuts. Reassemble in reverse order, ensure when fitting the combustion chamber that it is in contact with the base of the heat exchanger. Recharge the system as described in the Installation Instructions and check the joints for leaks.

27. AUTOMATIC AIR VENT (see Fig.1)

- a. Remove the outer casing, inner cover, fan and fluehood as described previously. See sequences 1,2,3,& 4 'Routine Maintenance'
- b. Close the central heating isolating valves, reduce the system pressure by opening the pressure relief valve, (access via wiring panel) then part drain the water from the boiler by removing the drain off screw (see Fig. 18).
- c. Unscrew using the body of the air vent and remove.
- d. Fit new air vent and sealing washer ensuring the air vent cap is left loose. Reassemble in reverse order and recharge the system as described in the Installation Instructions. Check for leaks.

28. PRESSURE RELIEF VALVE (See Fig. 22)

- a. Remove the outer casing as described previously, see sequence 1 'Routine Maintenance'.
- b. Swing open the control panel. (1 screw).
- c. Close the central heating isolating valves, reduce the system pressure by opening the pressure relief valve, (access via wiring panel) then drain the water from the boiler by removing the drain off screw (see Fig. 18).
- d. Undo both nuts on the pressure relief valve and remove.
Note. The outlet of the pressure relief valve is an olive connection.
- e. Replace with the new pressure relief valve using a new 'O' ring seal, reassemble in reverse order.
- f. Recharge the system and check for leaks.

29. WATER PRESSURE SWITCH (See Fig.18)

- a. Remove the outer casing as described previously. See sequence 1 'Routine Maintenance'.
- b. Close the central heating flow and return isolating valves. Reduce the pressure from the boiler by opening the pressure relief valve, (access via wiring panel). Drain the water from the boiler by removing the drain off screw (see Fig.18).
- c. Open the control panel (one screw) and remove the electrical connection from the switch terminals.

- d. Unscrew the switch from the pipe connection.
- e. Fit new switch using a new sealing washer.
- f. Reassemble in reverse order. Electrical polarity is not important. If there are three terminals, do not use the insulated tab.
- g. Open the isolating valves and re-charge the system as described in the installation instructions and check for leaks.

30. TRANSFORMER ASSEMBLY

- a. Remove the outer casing as described previously. See sequence 1 'Routine Maintenance'.
- b. Open the control panel (1 screw).
- c. Lower the wiring panel on the underside of the appliance (1 screw)
- d. Remove the transformer wiring harness plug from the top right hand side of the electronic control board and remove the wires from the retaining clips. (Note routing of wiring).
- e. Remove the two screws holding the transformer in position and remove from appliance.
- f. Fit the new transformer assembly in reverse order. It will be easier to replace the transformer by initially locating the upper screw into the transformer slot and using the transformer to position the screw to its threaded bush.

31. SIGHT GLASS WITH SECURING FRAME

- a. Remove the outer casing and inner cover as previously described. See sequences 1 and 2 'Routine Maintenance'.
- b. Remove all surplus silicone sealant from inside of inner cover and straighten the four retaining tags. Remove sight glass assembly. (Withdraw from the front of the inner cover).
- c. Renew the sight glass and securing frame, and use the new gasket each side of the glass to seal.
- d. Reassemble in reverse order using the silicone supplied with the kit to seal the tags.

FAULT FINDING (See Page 34)

Before attempting any electrical fault finding, carry out a preliminary electrical test by checking: for short circuits, fuse failure, incorrect polarity, earth continuity and resistance to earth.

For the replacement of faulty component, (see Section, - Component Replacement).

To assist in fault-finding, the logic sequence of the electronics control circuit precedes the fault-finding charts on Page 33.

FUNCTIONAL FLOW DIAGRAM

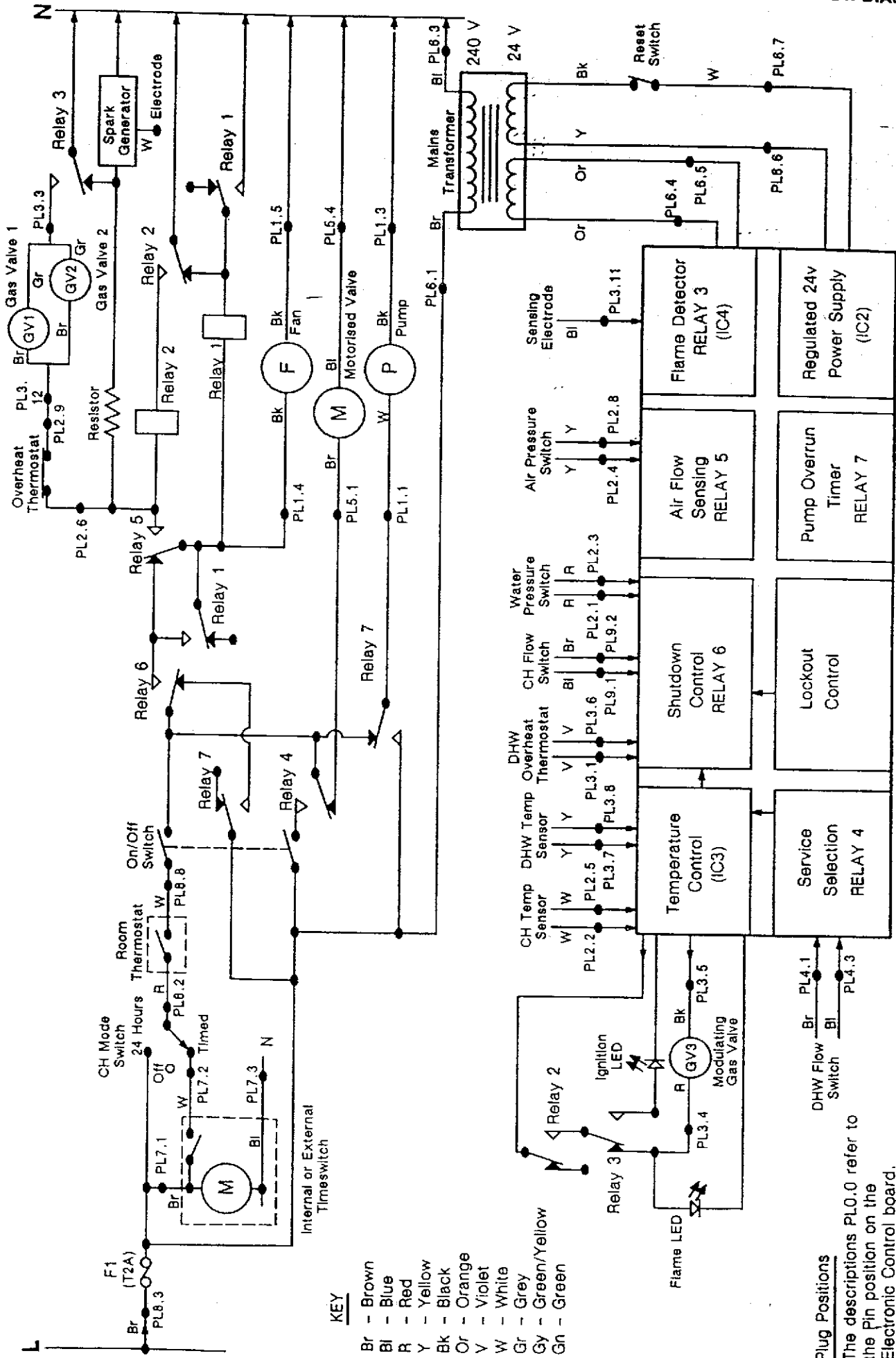

- KEY**
- Br - Brown
 - Bl - Blue
 - R - Red
 - Y - Yellow
 - Bk - Black
 - Or - Orange
 - V - Violet
 - W - White
 - Gr - Grey
 - Gy - Green/Yellow
 - Gn - Green

Plug Positions

The descriptions PL0.0 refer to the Pin position on the Electronic Control board. eg. PL4.3 indicates Plug 4, Pin 3 as marked on the control board.

PICTORIAL SCHEMATIC WIRING DIAGRAM

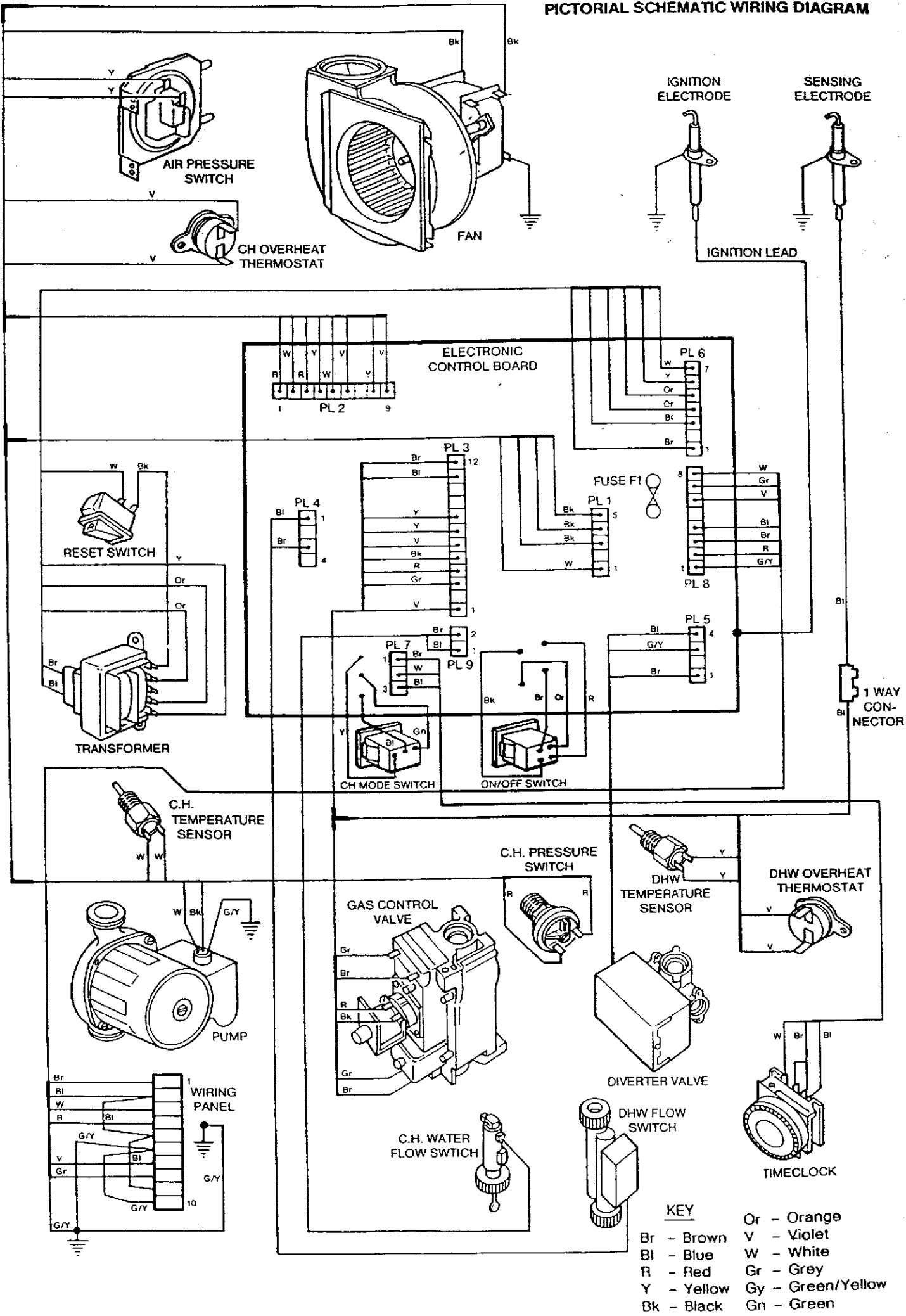

- KEY**
- Or - Orange
 - V - Violet
 - W - White
 - Br - Brown
 - R - Red
 - Y - Yellow
 - Bk - Black
 - Gr - Grey
 - G/Y - Green/Yellow
 - Gn - Green

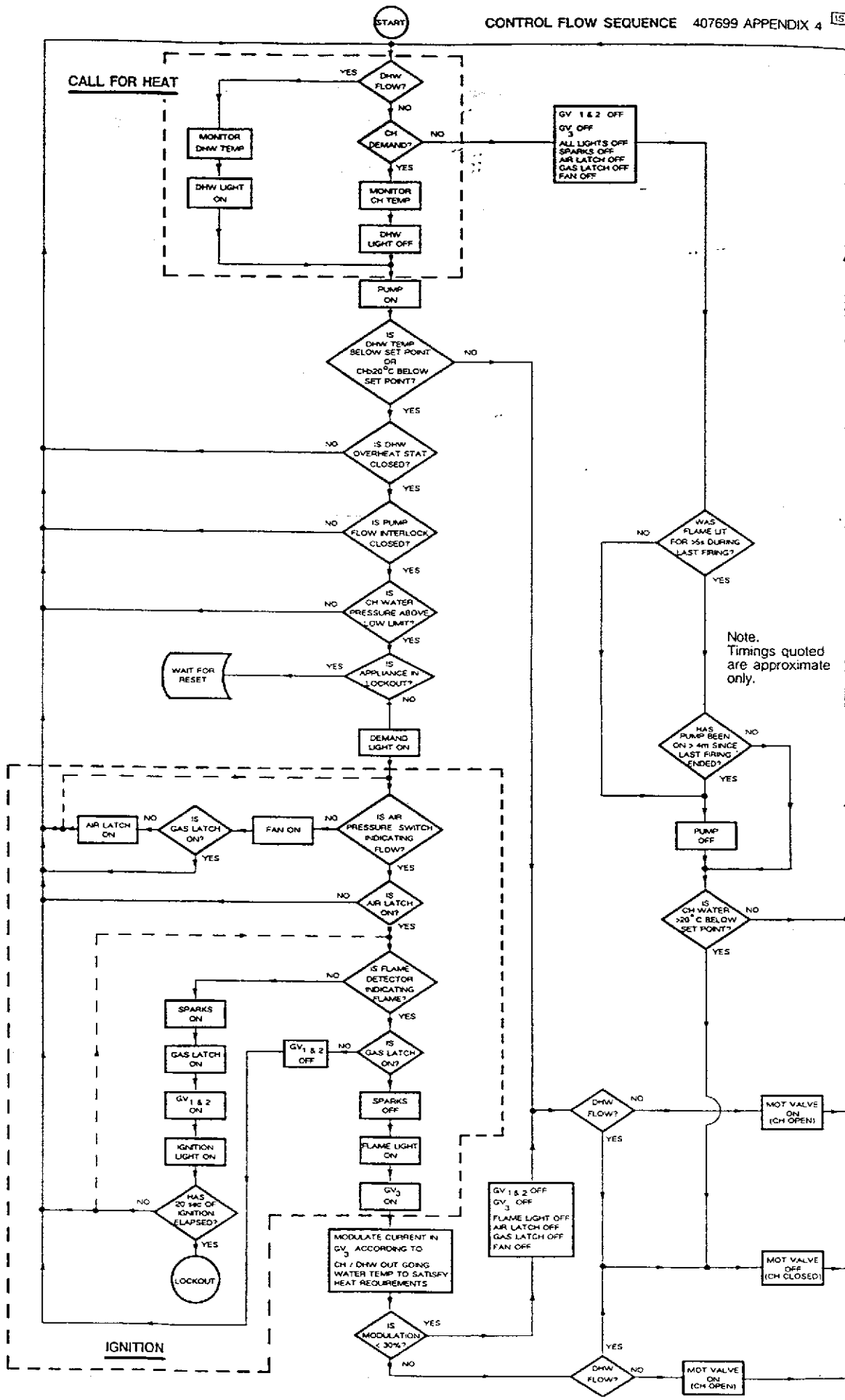

Note. Timings quoted are approximate only.

FAULT FINDER

Before Proceeding ensure all connections to the Electronic Control Board are fully pushed home.
Carry out preliminary electrical safety checks in accordance with 'Regulations for Electrical Installations.'

- a. Set main Boiler switch to OFF.
- b. Turn ON External Gas and Electricity supplies.
- c. Set D.H.W. and C.H. Thermostats to Maximum position.
- d. Set Mode Switch to CH24 Hours.
- e. Turn OFF all Hot Water Taps.

Diagram 1

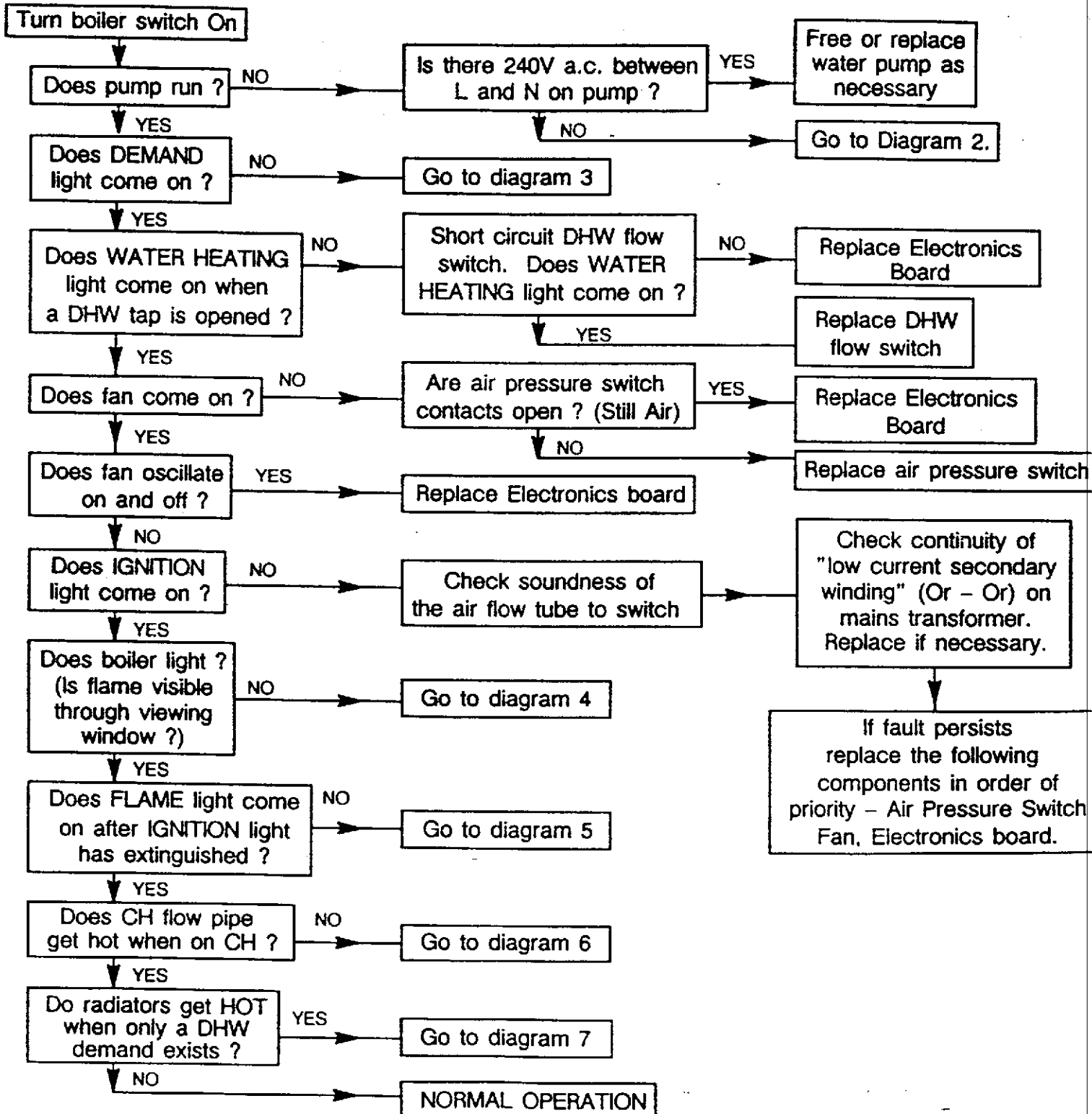

Diagram 2

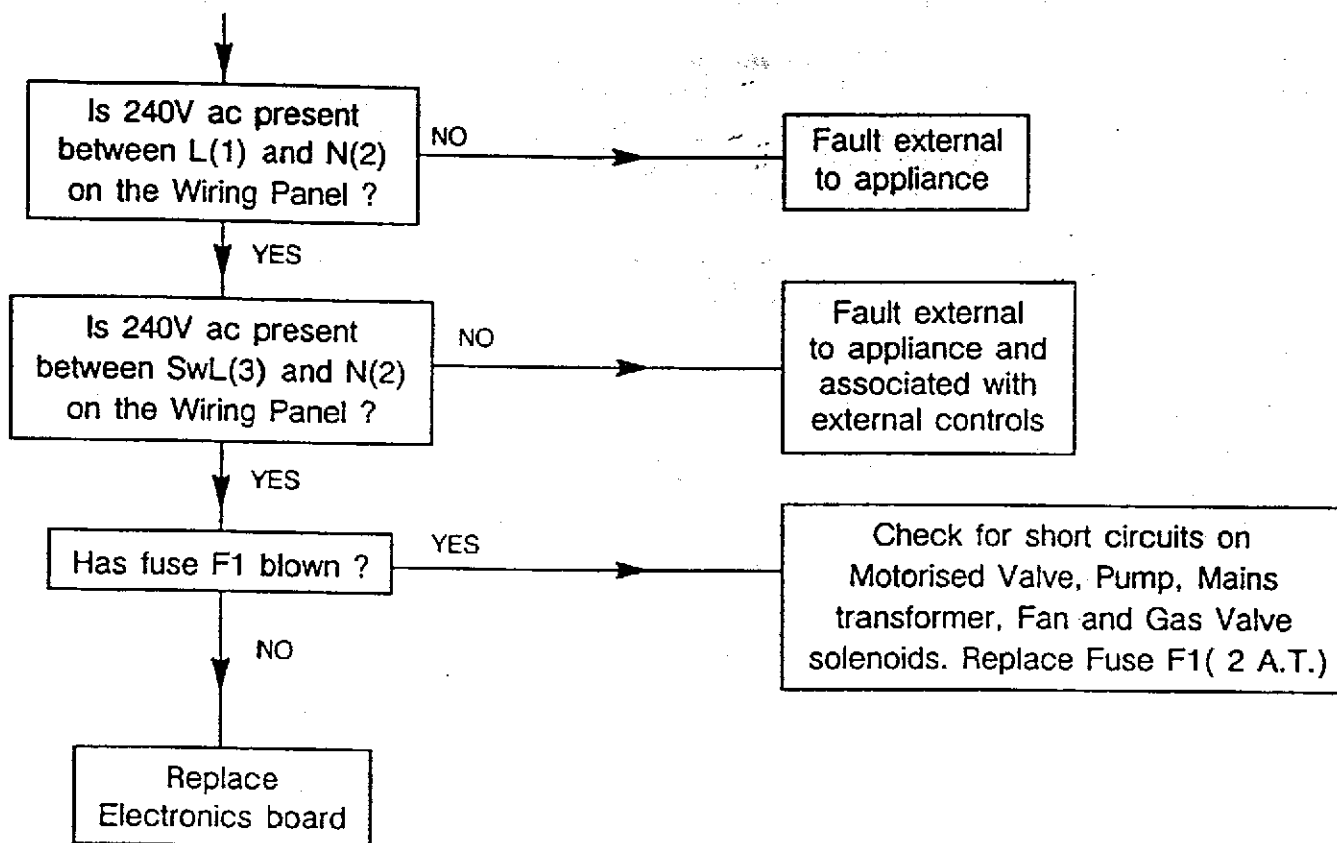

Diagram 3

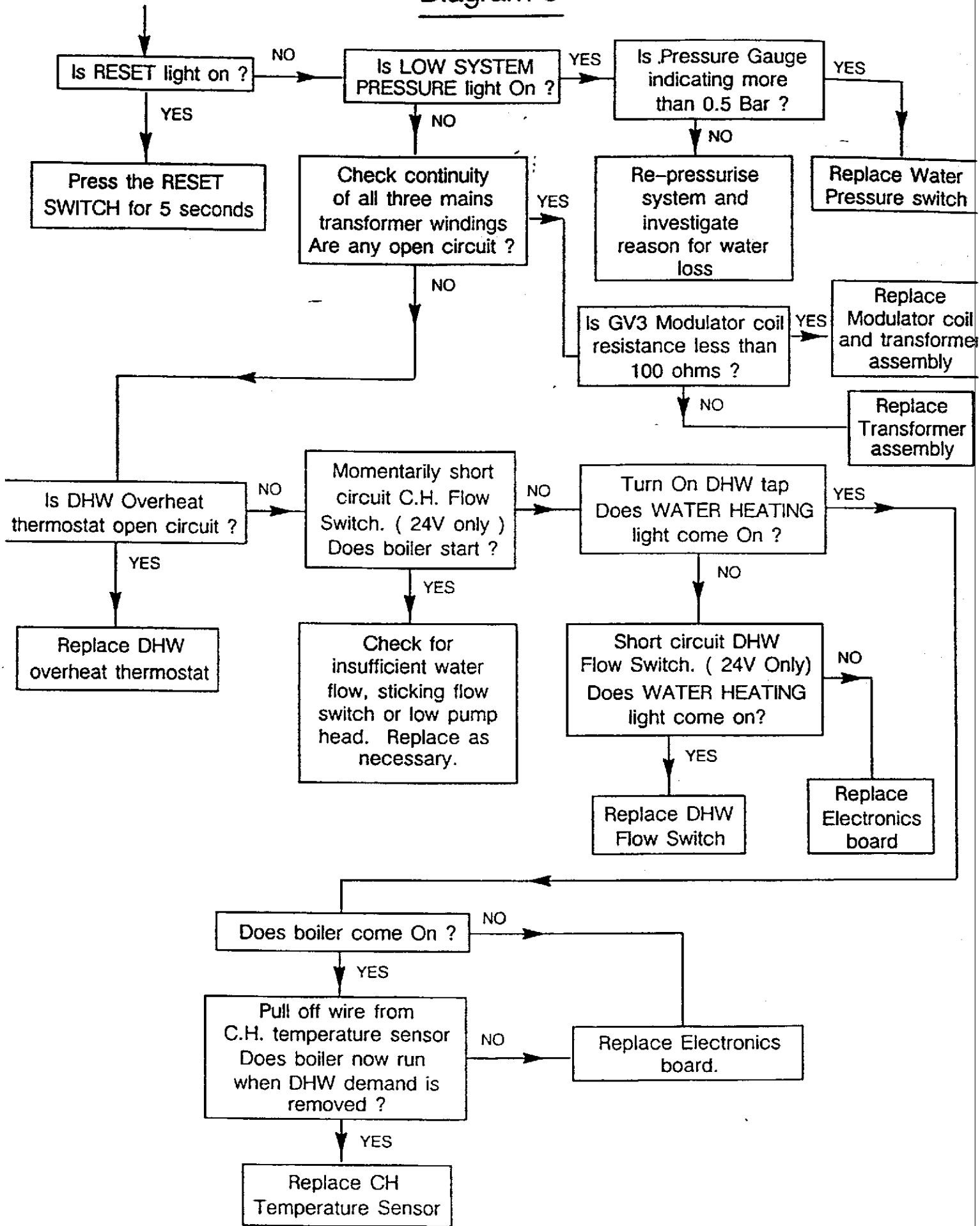

Diagram 4

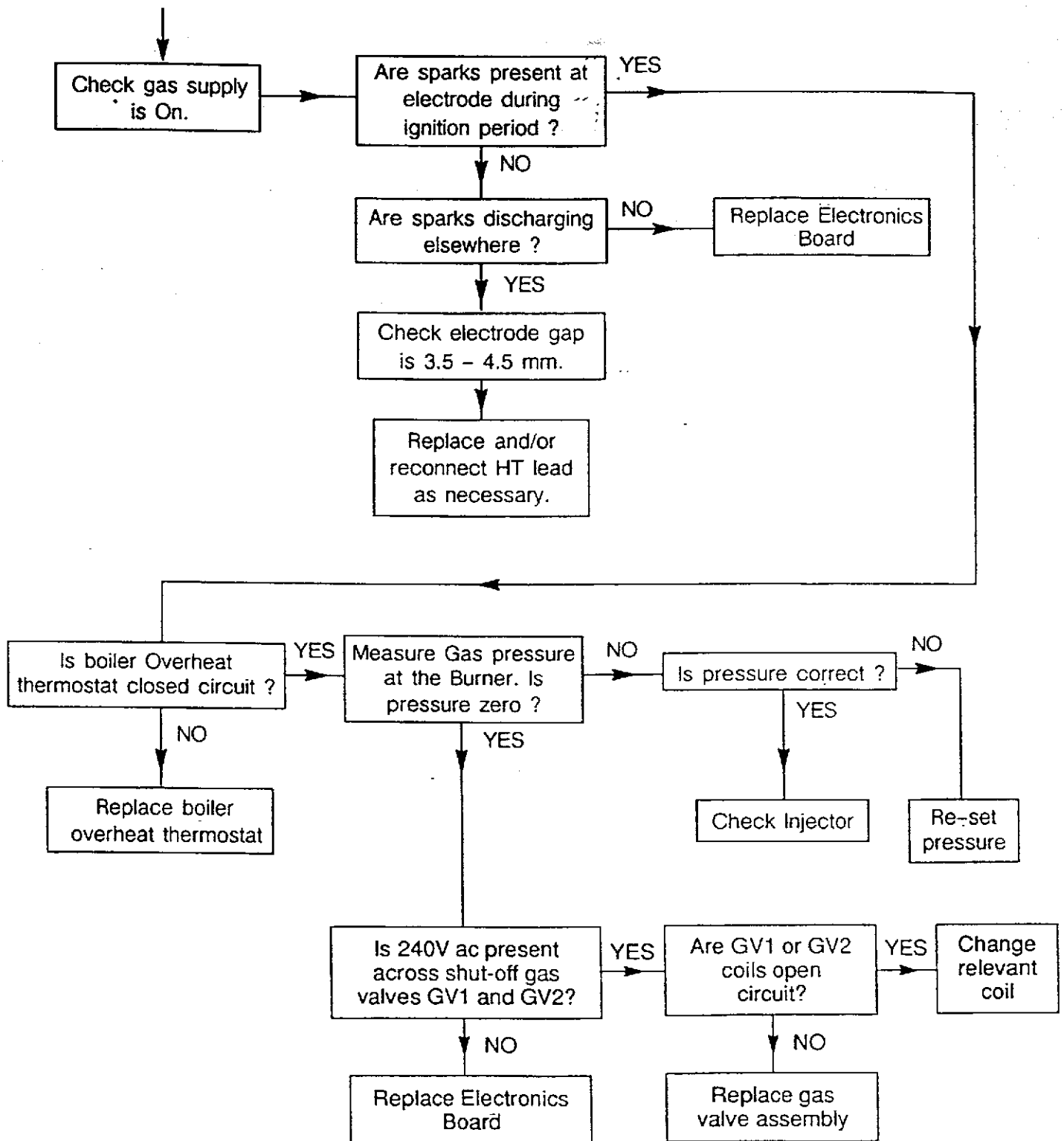

Diagram 5

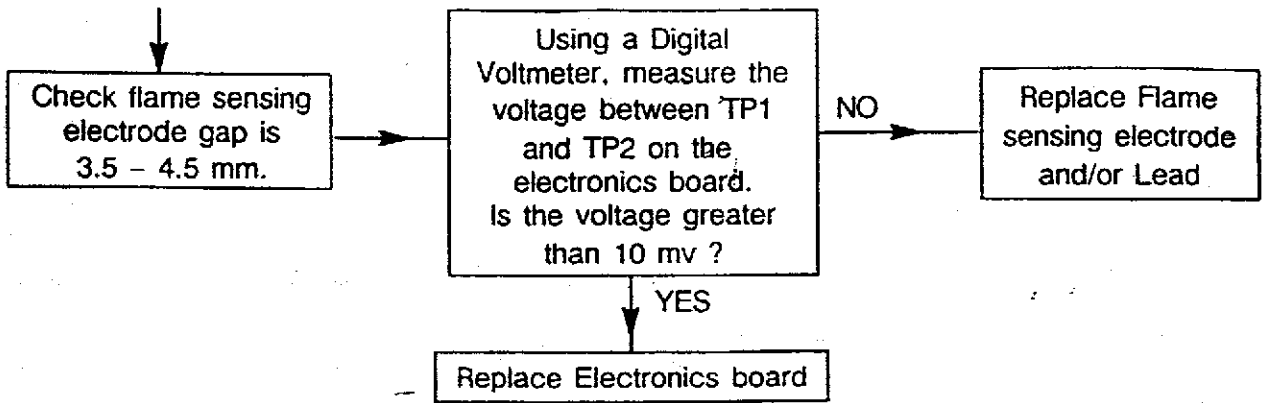

Diagram 6

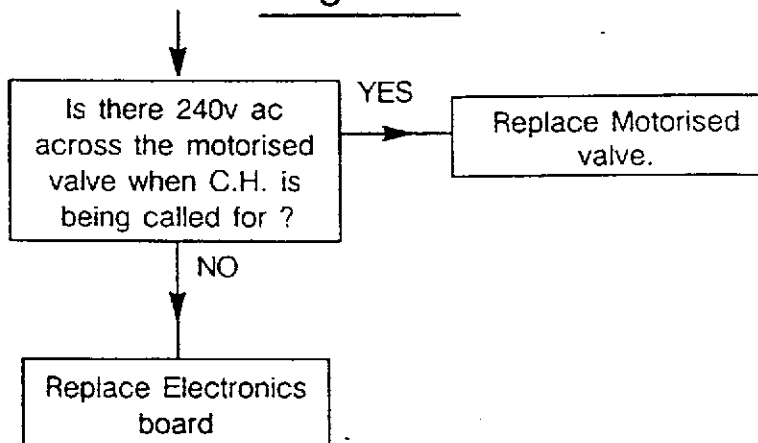
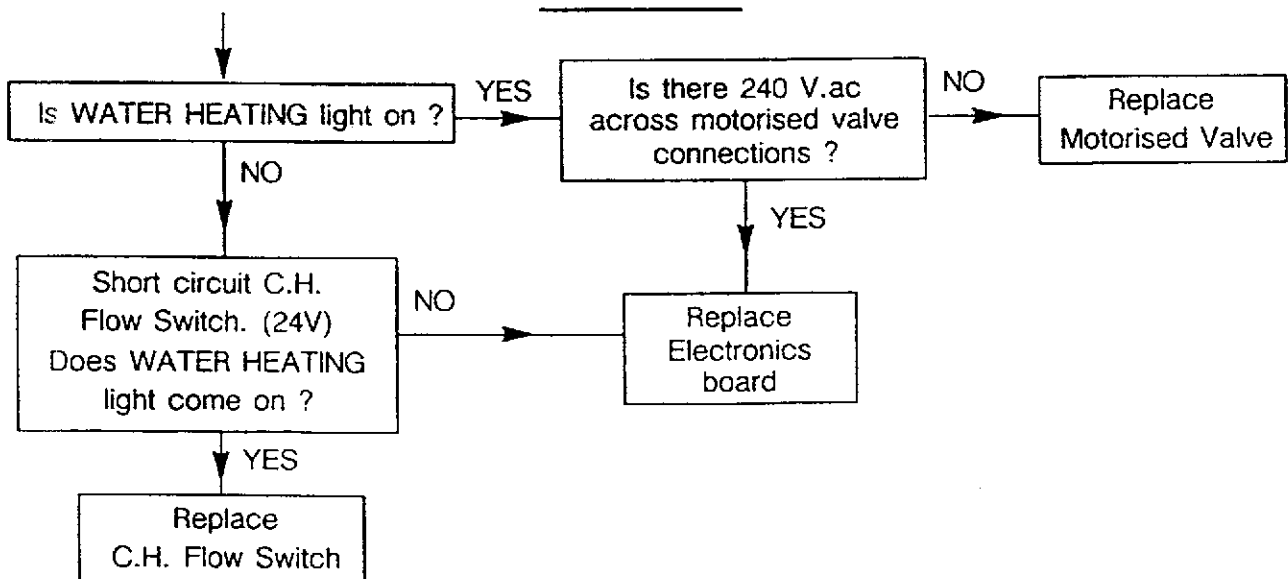
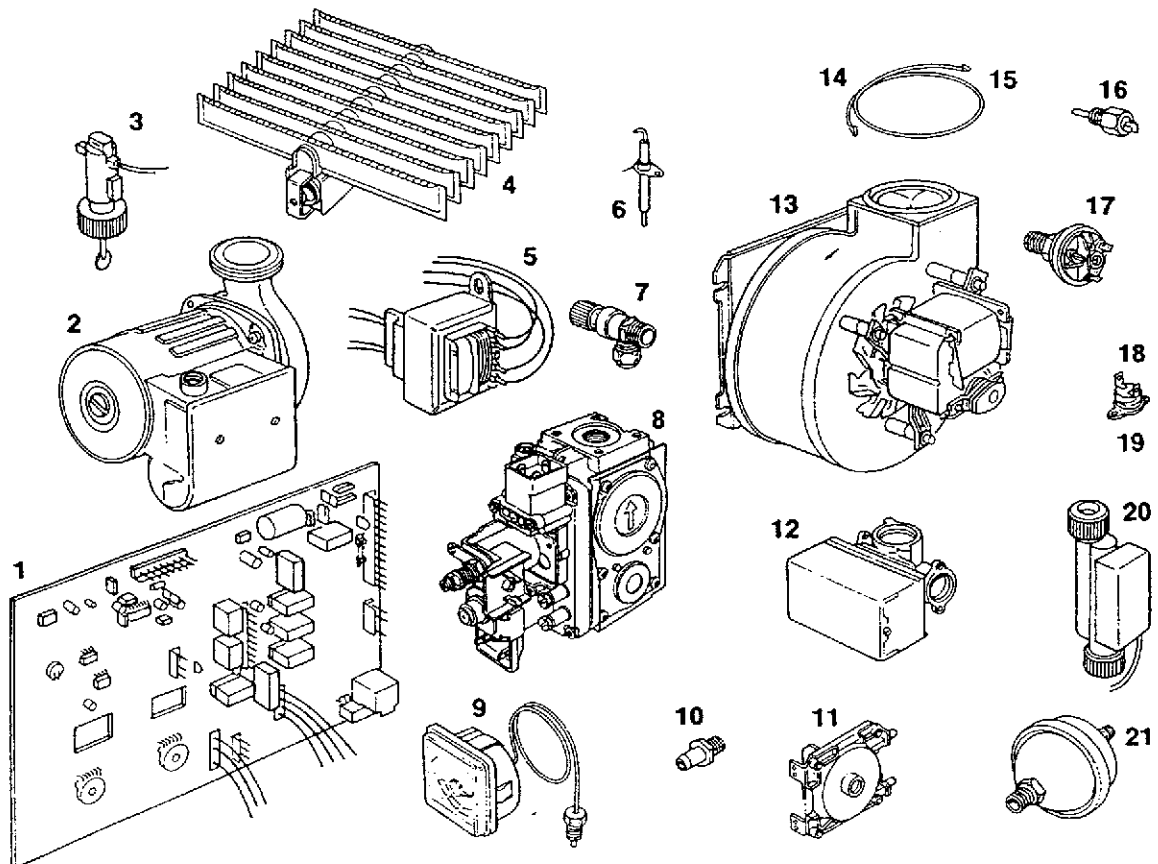

Diagram 7



SHORT PARTS LIST

Item	Description	Qty	Potterton Part No.	Gas Council Part No.
1	Electronic Control Board	1	407699	338 217
2	Pump (Euramo 'P')	1	411140	337 627
3	C.H. Water Flow Switch (c/w washer)	1	910022	332 236
4	Main Burner	1	414685	338 354
5	Transformer Assembly	1	222164	338 258
6	Electrode	2	407681	381 897
7	Pressure Relief Valve - 3 Bar (c/w washer)	1	910028	338 240
8	Gas Valve - SIT. Nova 827.123.	1	402979	378 768
9	Pressure Gauge (c/w washer)	1	910043	338 267
10	Burner Injector - 4.3mm	1	410997	378 771
11	Air Pressure Switch - Honeywell C4065A1007	1	642218	338 202
12	3 Way Diverter Valve - Honeywell-V4044C1577	1	430032	387 161
13	Fan Assembly-SEL (c/w Gaskets)	1	910002	338 205
14	Electrode Lead Assembly	1	407694	338 223
15	Flame Sensor Lead Assembly	1	407682	338 224
16	Water Temperature Sensor.CH & DHW. (c/w washer)	1	43001101	337 322
17	Water Pressure Switch (c/w washer)	1	910026	338 239
18	C.H Overheat Thermostat- Type 36-TE21-12354	1	404493	381 896
19	D.H.W Overheat Thermostat- Type 36-TE21-12381	1	404494	381 900
20	D.H.W Flow Switch (c/w fittings)	1	222131	338 250
21	D.H.W Expansion Vessel (c/w washer)	1	910040	338 257



"All descriptions and illustrations contained in this leaflet have been carefully prepared but we reserve the right to make changes and improvements in our products which may affect the accuracy of the information contained in this leaflet"

SALES INQUIRIES:

Sales Department
Eastern Avenue
Team Valley Trading Estate
Gateshead
Tyne & Wear
NE11 0PG

Tel: 0191 4917500
Fax: 0191 491 7568

SERVICE INQUIRIES:

Service Department
Brooks House
Coventry Road
Warwick
CV34 4LL

Tel: 08706 096096
Fax: 01926 410006

SPARES INQUIRIES:

Parts Division
Queensway
Leamington Spa
Warwickshire
CV31 3RG

Tel: 01926 880640
Fax: 01926 880680

TECHNICAL HELPLINE:

Technical Department
Brooks House
Coventry Road
Warwick
CV34 4LL

Tel: 08706 049049
Fax: 01926 410006

TRAINING ADMINISTRATION

Unit 5
Titan Business Centre
Spartan Close
Tachbrook Park
Leamington Spa
Warwickshire
CV34 6RS

Tel: 01926 430481
Fax: 01926 882971

Registered Office: 84 Eccleston Square . London SW1V 1PX

Registered in England No. 412935

"All descriptions and illustrations contained in this catalogue have been carefully prepared, but we reserve the right to make changes and improvements in our products which may affect the accuracy of the information contained in this catalogue"

O POTTERTON